

# RESOLVERS

Harowe

*FRAMED & FRAMELESS FEEDBACK DEVICES*



**Resolvers industriales**



## Mechanical and Electro-Mechanical Products

Danaher Motion engineers, manufactures and markets a select combination of the world's top brands of mechanical and electro-mechanical products. Our principal brands and products are listed to the right.

Designed to help increase productivity and improve performance, our products are incorporated into new equipment designs as well as machines already in service. From semiconductor assembly, packaging, robotics and industrial automation to medical, fitness and mobile off-highway equipment, our mechanical and electro-mechanical products bring flexibility, precision, efficiency, and reliability to a wide variety of industries.

Beyond our world-class product designs, one of our greatest strengths is our commitment to the Danaher Business System (DBS), which is comprised of a unique set of robust, repeatable processes that help us constantly improve the operational efficiency of our factories. Based upon the time-tested methods of Kaizen, the DBS is a team-based mindset that continuously and aggressively eliminates waste in every facet of our business operations. Furthermore, the DBS focuses the entire organization on breakthrough objectives that culminate in maintainable, results-oriented business processes, which, in turn, create advantages for our customers in the areas of quality, delivery and performance.

At Danaher Motion, we bring together best-in-class products, unsurpassed customization expertise, and innovative solutions to significantly improve and revolutionize the way things move. We are the experts in motion control. In short, Danaher Motion offers more choices, more application expertise and more integrated solutions than anyone else in the market.

Website:  
[www.DanaherLinear.com](http://www.DanaherLinear.com)

### **THOMSON™**

- Industrial, precision and rodless actuators, linear slide tables and systems, ball and lead screws, linear bearings and guides, precision balls, molded products, shafting and integrated solutions

### **THOMSON BSA™**

- Lead screws and precision miniature ball screws

### **MICRON**

- Gearheads

### **Harowe**

- Resolvers

### **Deltran**

- Electromagnetic friction clutches and brakes
- Wrap spring clutches and brakes

### **Superior Electric**

- Stepper and servo motors and controls

### **Seco AC/DC Drives**

- AC and DC variable speed drives

## Housed Brushless Resolvers

Harowe housed resolvers are available in a wide variety of electrical and mechanical configurations. Our brushless construction uses a rotary transformer to pass the reference signal to the rotor. This design eliminates the normal brush and slip ring sliding contact used in conventional resolvers. Since the brush and slip ring are life limiting components and can be a source of noise in harsh environments, the transformer coupled units enhance reliability and performance.

The industry-standard Size 11 resolver series has its own precision bearing system, making it ideal for coupling mounting. Alternately, the R11 shaft accepts pinions or pulleys for use in rack and pinion or cable measuring systems.

- Reliable in harsh environments
- Brushless construction—ideal mate for brushless servo motors
- Excellent angular accuracy & repeatability
- Maintenance free
- Shortest length in industry for easy packaging
- Temperature rating of 155°C for high temp applications
- Ideal for use in high shock applications

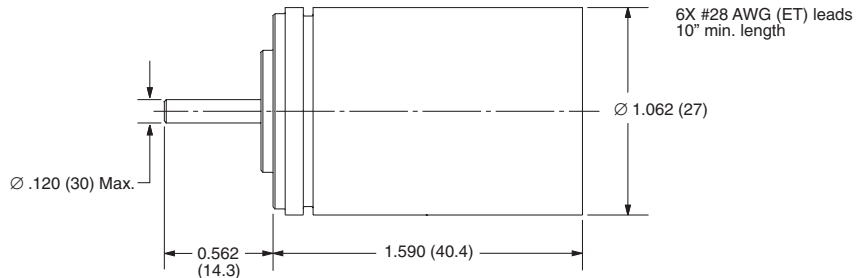

Family Model	Speed*	Primary Winding	Accuracy ± Arc-Min	Input Voltage (Vrms)	Frequency (Hz)	Maximum Input Current (mA)	Transformation Ratio (V out/ Vin) ± 10%	Phase Shift (degrees)	Total Null Voltage (mV)
11BRW-300-B	1	Stator	10	12.0	400	10.9	1.75	12	30
11BRW-300-F	1	Stator	7	12.0	2,500	3.1	0.50	-2	30
11BRW-300-M	1	Stator	7	10.0	5,000	8.3	0.50	-5	30
11BRCT-300-F	2	Stator	10	12.0	2,500	8.3	0.50	0	15
11BRCT-300-M	2	Stator	10	11.8	2,500	70.0	1.02	-1	30
11BRCT-300-T	4	Stator	5	12.0	2,500	6.0	0.53	-2	15
11BRCT-300-P	5	Stator	4	12.0	2,500	1.4	0.39	-7	15
11BRCX-300-A	1	Rotor	7	7.5	4,000	13.5	0.54	-2	20
11BRCX-300-B	1	Rotor	7	7.5	4,000	40.0	1.07	-2	15
11BRCX-300-C	1	Rotor	7	6.0	1,000	15	0.45	4	15
11BRCX-300-G	1	Rotor	7	26.0	400	40.0	0.45	12	30
11BRCX-300-J	1	Rotor	7	7.0	5,000	10.9	0.95	-6	15
11BRCX-300-N	1	Rotor	7	8.5	1,000	14.0	1.00	3	30
11BRCX-300-M	2	Rotor	7	7.0	5,000	10.9	0.95	-2	30
11BRCX-300-T	4	Rotor	7	7.0	5,000	11.0	0.84	7	20
11BRCX-300-P	5	Rotor	6	10.0	5,000	5.0	0.55	-3	20
R11-S01F-1A	1	Rotor	20	1.88	2,250	21.0	1.40	11	15
R11-S01F-1B	1	Rotor	20	6.00	2,000	12.0	0.454	8.5	15
R11-S01F-1A	1	Rotor	6	1.88	2,250	21.0	1.40	11	15

\*Speeds are defined as follows: 1 = single speed; 2 = 2-speed; etc.

## R25 Heavy-Duty Industrial Resolvers

The Harowe R25 heavy duty brushless resolvers are designed for reliability in adverse operating conditions. Resolvers are the better choice over encoders for applications that involve very high temperature, vibration and shock and/or dirty environments. R25s will quickly recover their cost by eliminating frequent downtime caused by less robust transducers. You can trust the R25 to operate reliably 24 hours a day, 365 days a year in the worst industrial environments.

Unlike similar duplex-bearing packages, the R25 uses a front-and-rear bearing arrangement. This provides from two to three times the radial load bearing capacity and up to ten times the L10 life of a package with duplex bearings. The increase in load bearing capacity applies equally to static, dynamic, and shock loading.

- Rugged housing with IP-65 protection rating
- Ideal for high temperatures, high shock environments
- Standard MS-style connectors
- Flange- and servo-mount styles
- Shielded, spaced-support bearings provide up to 10X the life of duplex bearings
- Excellent noise immunity
- Standard +125°C continuous duty operating rating
- Corrosion resistant finishes
- Accuracy grades from  $\pm 7$  to  $\pm 20$  arcmin
- Withstands shock to 200g, vibration to 40g

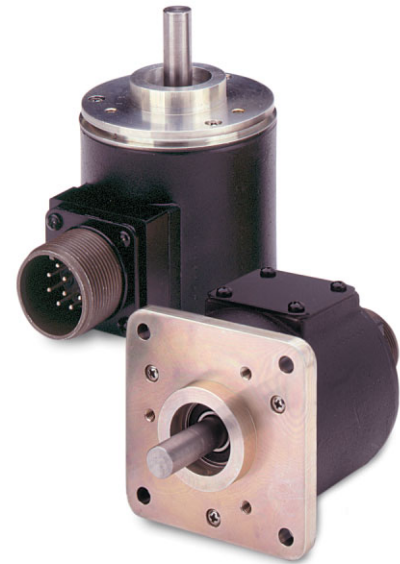

Elec. Kit	Speed (No. of Poles)	Xformer Ratio (V in/V out)	Input Voltage (Vrms)	Max. Curr. Input (mA)	Ref. Freq. (Hz)	Phase Shift (min)	Pri. Wndg.
1A	1 (2)	0.500	5.3	3	4000	-3	Stator
1B	1 (2)	0.500	4.0	25	5000	-6	Rotor
1C	1 (2)	0.470	4.25	55	7000	+4 $\pm$ 3	Rotor
1D	1 (2)	0.500	7.0	25	2500	+6	Rotor
1E	1 (2)	0.950	7.0	12	5000	-3	Rotor
1F	1 (2)	1.000	2.0	10	5000	-8	Rotor
2A	2 (4)	0.250	8.0	20	4000	+5.5 $\pm$ 3	Rotor
3A	3 (6)	0.470	4.25	55	7000	+5 $\pm$ 3	Rotor

<b>Inertia</b>	0.0040 oz-in-sec <sup>2</sup>
<b>Friction</b>	2 oz-in (5 oz-in w/shaft seal)
<b>Shaft Load (max.)</b>	40 lb (axial), 60 lb (radial)
<b>Shaft</b>	#416 S/S
<b>Material</b>	
<b>Play (max.)</b>	Radial: .0015 in @ 1 lb load; End: .005 in @ 5 lb load
<b>Bearing Life</b>	2 x 10 <sup>8</sup> revs at rated shaft loading

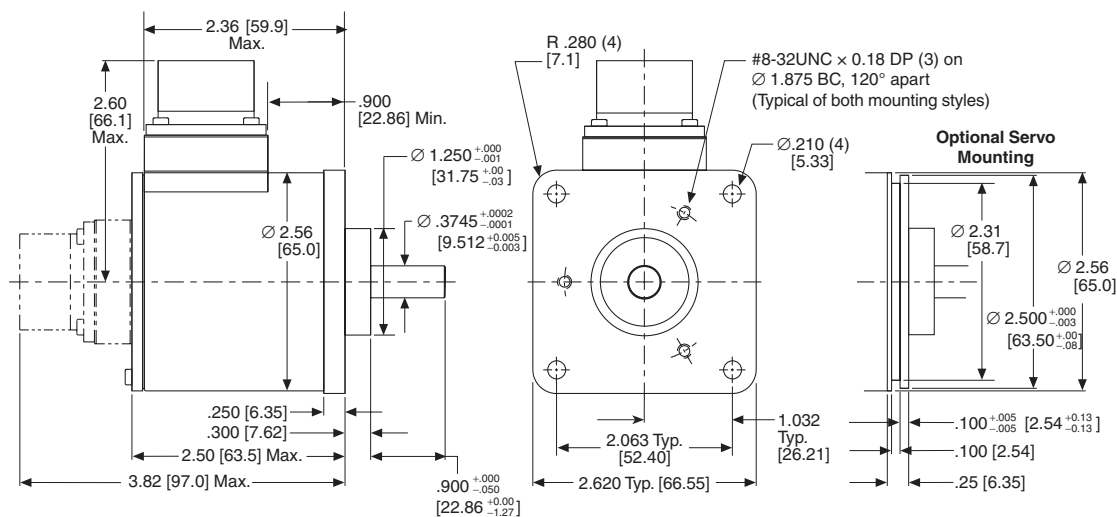

## R25 Series Model Numbering

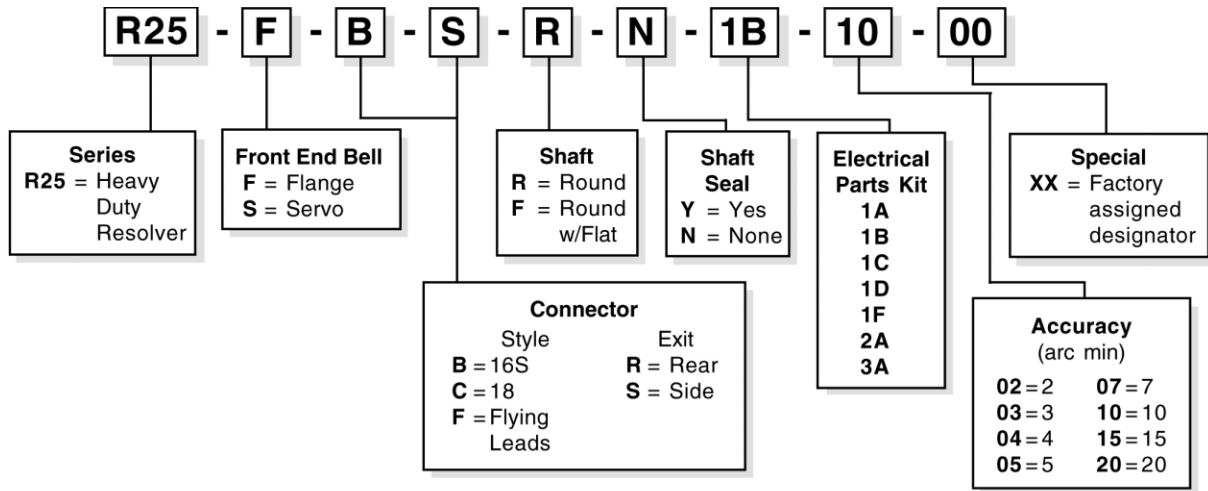

## Connector and Cable Accessories

MS3106-style connectors and cable assemblies are offered to mate with Harowe heavy-duty R25 resolver packages.

Cables are low capacitance type (13 pF/ft) with individually shielded twisted pairs. They are available in one foot incremental lengths as standard, and custom lengths by special order.

Pin outs match the R25 and are consistent with industry standards for size 25 resolver packages.

### MS3106F-16S-1S Connector

Pin	Signal	Cable Lead Color
A	R1 (Rotor Hi)	White
B	R2 (Rotor Lo)	Black w/White
C	S1 (Cos Hi)	Green
D	S3 (Cos Lo)	Black w/Green
E	S4 (Sin Lo)	Blue
F	S2 (Sin Hi)	Black w/Blue
G	Open	

### MS3106F-18-1S Connector

Pin	Signal	Cable Lead Color
A	R1 (Rotor Hi)	White
H	R2 (Rotor Lo)	Black w/White
B	S1 (Cos Hi)	Green
I	S3 (Cos Lo)	Black w/Green
C	S4 (Sin Lo)	Blue
J	S2 (Sin Hi)	Black w/Blue
G	Open	

### R25 Basic Schematic

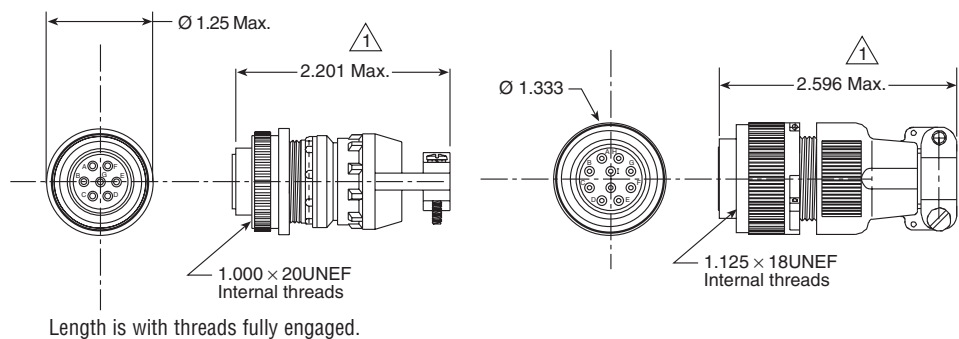
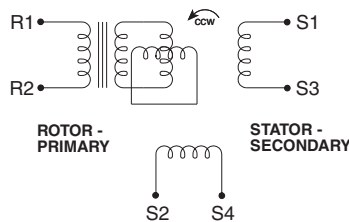

Use of Harowe mating connectors and low capacitance cable is recommended (or equivalent such as Belden 8163 cable with twisted-pairs for R1/R2, S1/S3 and S2/S4).

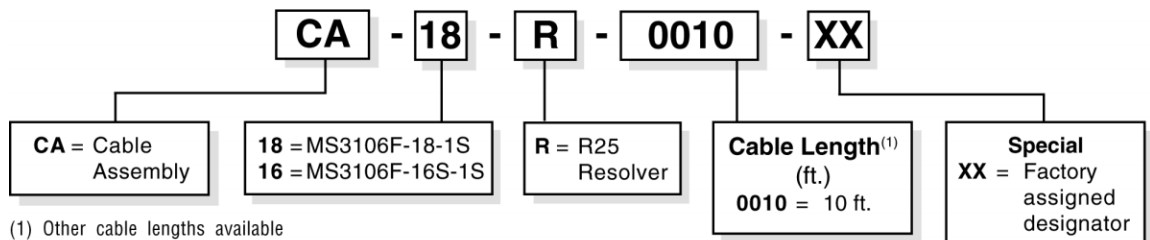



## Frameless Brushless Resolvers

Harowe brushless resolvers are the ideal position feedback transducer for brushless motors, robots and direct-drive motors in precision rotary platforms and similar servo applications.

Resolvers are the most versatile position transducers available for instrumenting rotary axes. They are rugged, reliable, able to operate at 155°C and impervious to most particulate and liquid process contaminants. In addition, resolvers provide absolute position information over one revolution (single speed types), and can be combined with an inexpensive integrated circuit to provide up to 16-bit digital word or emulated incremental encoder output, plus direction and analog velocity signals.

- Provide accurate, absolute position feedback
- Rugged and able to withstand high shock and vibration levels
- Highly resistant to EMI noise and radiation effects
- Impervious to most industrial contaminant and temperature extremes
- Brushless, lightweight devices that consume little power

### Options

- Multiple speeds available (up to 32 on Size 55)
- Flux shielding technology
- Steel or aluminum housings
- Radiation hardened
- High temperature up to 220°C
- Flanged or Servo-groove mounting

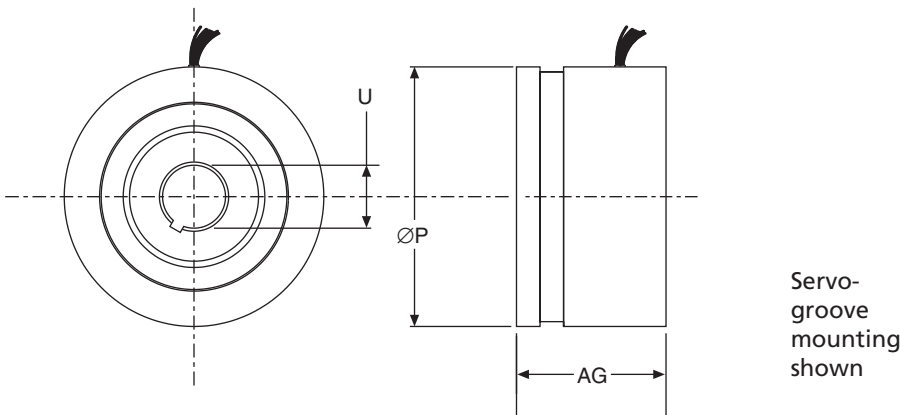

Model*	AG in (mm)	P in (mm)	U in (mm) Max
10BRCX	.65 (16.5)	1.05 (26.5)	.237 (6.0)
15BRCX	1.00 (25.4)	1.45 (36.8)	.472 (12.0)
21BRCX	1.25 (31.8)	2.06 (52.4)	.8007 (20.34)
31BRCX	1.25 (31.8)	3.05 (77.5)	1.5763 (40.04)
55BRCX	1.25 (31.8)	5.50 (139.7)	3.6515 (92.75)

\*Available as transmitter and control transformer types.

## INTRODUCING... The New 700 Series HaroMax Resolvers

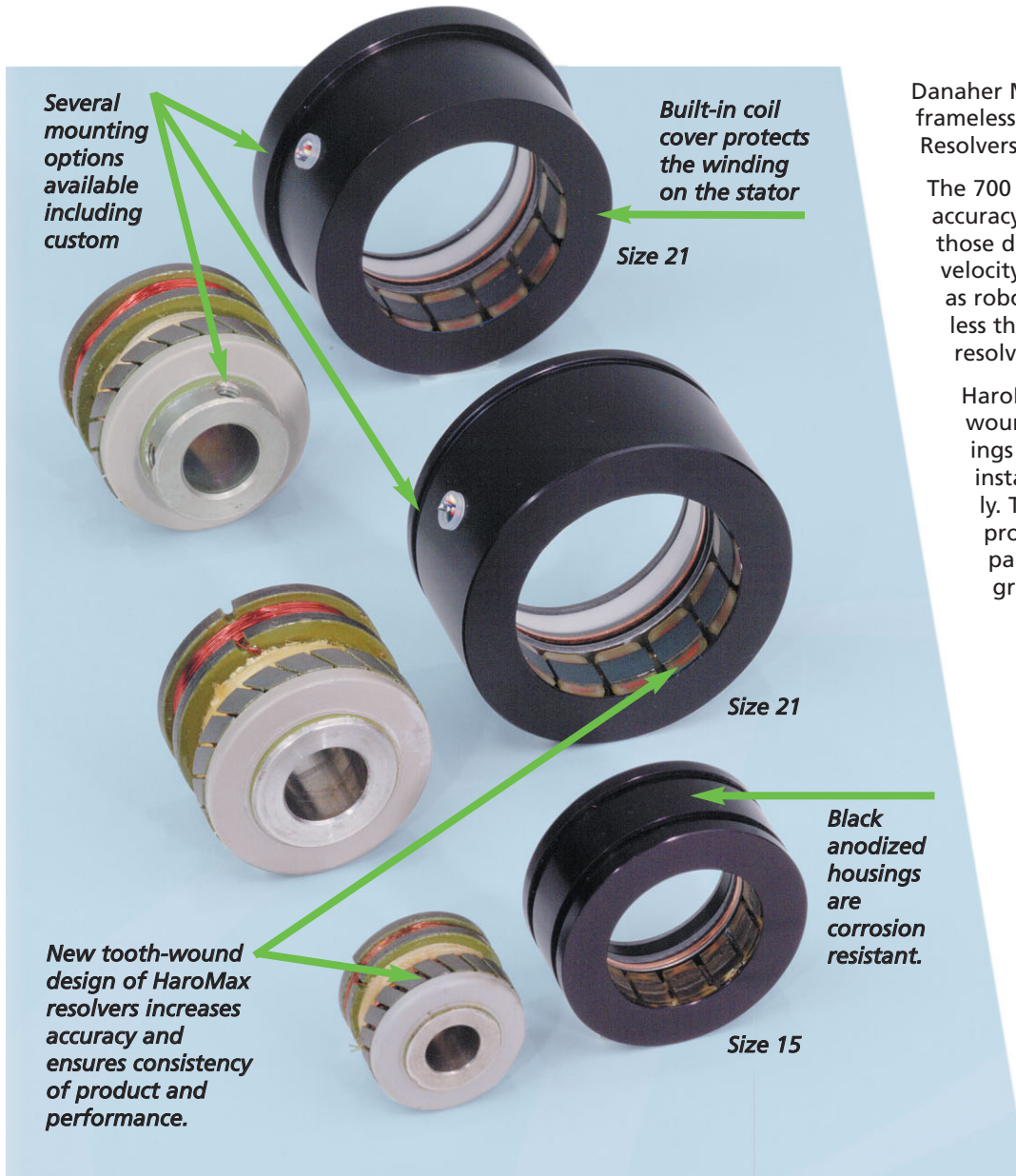

Danaher Motion introduces its newest frameless, brushless resolver: HaroMax Resolvers in sizes 15 and 21.

The 700 Series provides maximum accuracy and minimum error for those demanding position and velocity feedback applications such as robotics. Electrical error is 50% less than that of a standard resolver.

HaroMax Resolvers' new tooth-wound design incorporates windings that are manufactured and installed completely automatically. The automatic installation provides the least amount of part-to-part variation for the greatest consistency.

Danaher Motion is the leading North American manufacturer of frameless brushless resolver feedback products. For over fifty years, Harowe brand resolvers have been providing feedback solutions. Technical experience and design/manufacturing expertise are built into every Harowe resolver.

# Danaher Motion Linear Motion Systems

As part of the Danaher Motion family, our mechanical and electro-mechanical product offerings include standard and custom linear bearings, shafting, linear guides, ball and lead screws, gearheads, linear actuators, slide tables and systems, precision balls, molded products, resolvers, brakes and clutches, AC and DC adjustable speed drives, stepper and servo motors. Our products are applied worldwide throughout a variety of motion applications in the machine tool, medical, automotive, robotics, industrial, aerospace, office equipment and mobile off-highway markets. Our highly recognized brand names include: Thomson™, Thomson BSA™, Micron™, Harowe™, Deltran PT™, Superior Electric™ and SECO™.



## Harowe

**DANAHER**  
MOTION *Solutions by*

\* Trademark of Danaher Motion. DANAHER MOTION is registered in the U.S. Patent and Trademark Office and in other countries. The specifications in this publication are believed to be accurate and reliable. However, it is the responsibility of the product user to determine the suitability of Harowe products for a specific application. While defective products will be replaced without charge if promptly returned, no liability is assumed beyond such replacement. ©2003 Danaher Motion. HKM 5K GH 6-5-03 200306-Resolvers.qxd HR-01-01-G101

### FOR IMMEDIATE ASSISTANCE:

Internet:	<a href="http://www.DanaherLinear.com">www.DanaherLinear.com</a>	In Europe:	Phone: +46 (0) 44 24 67 00 Fax: +46 (0) 44 24 40 85 E-mail: <a href="mailto:helpdesk@tollo.com">helpdesk@tollo.com</a>
In USA, Canada or Mexico:	Phone: 1-800-554-8466 Fax: 1-800-445-0329 E-mail: <a href="mailto:thomson@danahermotion.com">thomson@danahermotion.com</a> Literature: <a href="mailto:litrequest@danahermotion.com">litrequest@danahermotion.com</a>	or write:	Danaher Motion Tollo Linear AB Box 9053 SE-291 09 Kristianstad Sweden
or write:	Danaher Motion 43-45 Channel Drive Port Washington, NY 11050 USA	or	Phone: +49 (0) 70 22 504-0 Fax: +49 (0) 70 22 541-68 E-mail: <a href="mailto:Kontakt@warner-electric.de">Kontakt@warner-electric.de</a>
In UK:	Phone: + (44) 1271 334 500 Sales Fax: + (44) 1271 334 502 E-mail: <a href="mailto:information@tiblmail.com">information@tiblmail.com</a>	or write:	Warner Electric GmbH Nürtinger Strasse 70 D-72649 Wolfschlügen Germany
or write:	Danaher Motion Thomson IBL Company Westacott Toad, Barnstaple Devon, EX32 8TH England	Elsewhere:	Phone: 1 (516) 883-8937 Fax: 1 (516) 883-7109