

Instruction Manual

Universal Vibration Monitor

M12

Version B



Manfred Weber

Metra Mess- und Frequenztechnik in Radebeul e.K.

Meissner Str. 58 - D-01445 Radebeul / Germany

Phone +49-351 849 21 04 Fax +49-351 849 21 69

Email: Info@MMF.de Internet: www.MMF.de

Published by:

Manfred Weber
Metra Mess- und Frequenztechnik in Radebeul e.K.
Meißner Str. 58
D-01445 Radebeul / Germany
Tel. +49-351-836 2191
Fax +49-351-836 2940
Email Info@MMF.de
Internet www.MMF.de

Notice: The latest version of this manual can be found at
<http://www.mmf.de/produktliteratur.htm>

© 2007 Manfred Weber Metra Mess- und Frequenztechnik in Radebeul e.K.

Contents

1. The M12 at a Glance.....	5
2. Purpose.....	6
Measured Vibration Quantities.....	6
Outputs.....	6
Filters.....	6
LED Indicators.....	6
3. Function.....	7
Sensor Input.....	7
Amplifier.....	7
Filters.....	8
Integrators.....	8
RMS Rectification.....	8
Peak-to-Peak Rectification.....	8
DC Outputs.....	8
4-20 mA Loop Output.....	8
Alarm Relay.....	8
Level Display.....	9
Self Test Functions.....	10
AC Output.....	10
Overload Indication.....	10
Power Supply.....	10
Triple Insulation.....	10
4. Installation.....	11
4.1. Preparing Measuring Points.....	11
Sensor Location.....	11
ISO 10816-1.....	12
4.2. Installation and Adjustment.....	13
4.2.1. Attachment.....	13
Terminals.....	14
4.2.2. Power Supply.....	14
4.2.3. Sensor.....	14
Sensor Input.....	14
Sensitivity Adjustment.....	15
Sensor Status Indication.....	15
Sensor Connection.....	15
Operation of Two M12 Modules with One Sensor.....	16
4.2.4. Selecting a Vibration Quantity.....	17
Dynamic Range of the Integrators.....	18
RMS /	
Peak-to-Peak.....	19
4.2.5. Selecting the Measuring Range.....	19
Overload Indication.....	19
4.2.6. Plug-in Filters.....	20
Slope.....	20

Factory Configuration.....	20
Replacing Filter Modules.....	20
4.2.7. Relay Output.....	21
Adjustments.....	21
Connection of the Relay Output.....	22
Self Test Function.....	22
Sensor Monitoring.....	22
Contact Rating.....	23
4.2.8. Current Loop 4-20 mA Output.....	23
Connection.....	24
Insulation.....	24
False Polarization.....	24
4.2.9. DC Outputs.....	25
4.2.10. AC Output.....	26
Filtering and Integration.....	26
Settings.....	26
Output Level.....	27
Bandwidth.....	28
Connection.....	28
4.3. Calibration.....	29
Factory Calibration.....	29
Calibration Point.....	29
Vibration Calibrator.....	29
Electrical Calibration.....	29
4.4. Vibration Level Display M12DIS.....	30
Connection.....	30
LED Backlighting.....	30
Mounting.....	31
Calibration.....	31
5. Measuring Methods for Machine Vibration.....	32
5.1. Vibration Severity Measurement for Unbalance.....	32
ISO 10816-1.....	32
Measurement with the M12.....	33
5.2. Vibration Measurement on Reciprocating Engines.....	34
DIN/ISO 10816-6.....	34
Measurement with the M12.....	35
5.3. Bearing Monitoring.....	35
General.....	35
Crest Factor.....	35
Diagnostic Coefficient.....	36
Measurement with the M12.....	36
6. Technical Data.....	37
Appendix: Warranty	
Declaration of CE Conformity	

1.The M12 at a Glance

Front View:

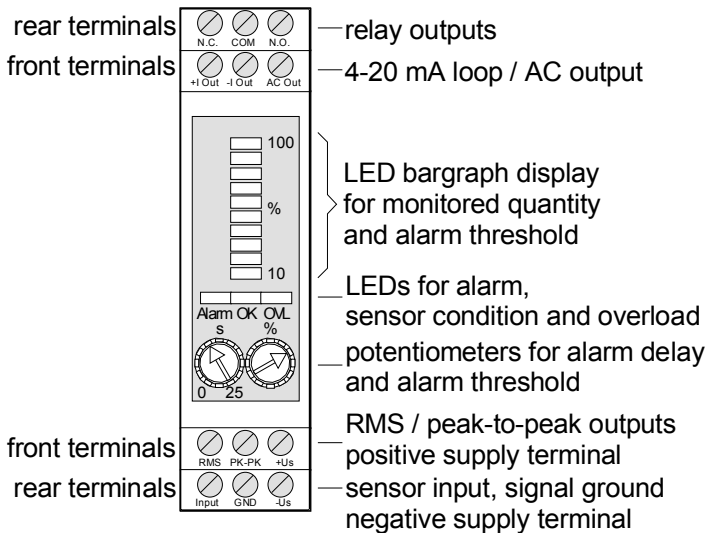

Side View:

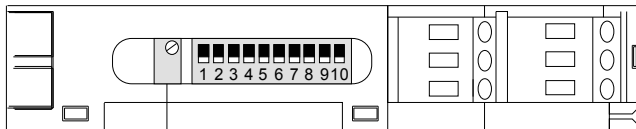

Adjustment of transducer sensitivity

Function of the DIP switches in their lower position:

- 1: Sensor supply on
- 2: Range 10
- 3: Range 50
- 4: Range 250
- 5: Double integration (displacement)
- 6: Single integration (velocity)
- 7: Integration off (acceleration)
- 8: RMS monitoring
- 9: Peak-to-peak monitoring
- 10: Alarm duration short

2.Purpose

The Universal Vibration Monitor is suitable for applications where vibrations need to be monitored or measured. Typical applications include condition monitoring of rotating machinery to ISO 10816 and bearing monitoring. The M12 provides information about the running condition of a machine. Thereby it helps the maintenance engineer to predict wear in time and to avoid unexpected breakdown. Thus the M12 can reduce cost caused by production loss and unnecessary repairs. The M12 can also be used for many tasks in process and quality control.

Its flexible design makes it easy to adapt the M12 for any monitoring application. This can be of particular advantage if no information about the vibration signal and its frequency components is available before installation.

The M12 provides standardized output signals for further processing. A relay output for shut-off functions or alarm messages is also available.

Measured Vibration Quantities

The M12 is designed for operation with an IEPE compatible piezoelectric accelerometer. It can be used for measuring the following quantities

- Vibration acceleration (without integration)
- Vibration velocity (single integration)
- Vibration displacement (with double integration)

For each vibration quantity among 3 measuring ranges can be chosen.

Outputs

The vibration signal is available at the following outputs:

- AC wide band output of amplified but unfiltered sensor signal
- AC output of amplified, filtered and, if necessary, integrated sensor signal
- DC output of true RMS for selected vibration quantity
- DC output of peak-to-peak value for selected vibration quantity
- 4-20 mA current loop output of RMS or peak-to-peak value for selected vibration quantity

Filters

The use of replaceable filter modules makes the M12 particularly versatile. High pass and low pass frequencies can be selected individually by means of an extensive range of available filter modules.

LED Indicators

The following LED indicators can be found at the front panel:

- Alarm LED
- Sensor status LED
- Overload LED
- LED bar graph for monitored vibration quantity and alarm threshold

3.Function

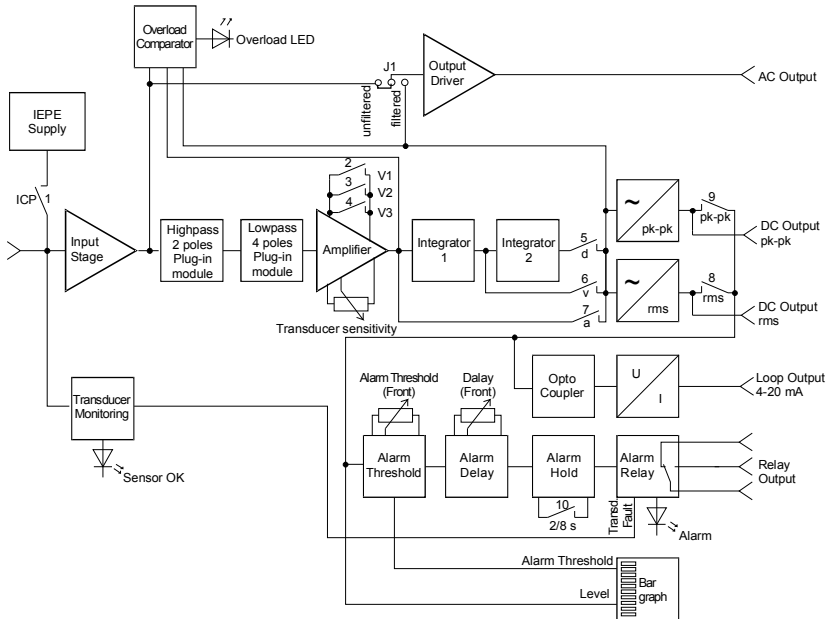

Figure 1: Block diagram

Sensor Input The M12 requires for operation a piezoelectric accelerometer with integrated electronics to IEPE standard. The instrument is factory calibrated for standard industrial accelerometers with 100 mV/g sensitivity, for example Models KS80 or KS81 of Metra with protection grade IP67 and insulated case. The constant current for the integrated sensor electronics is supplied by the M12 and can be activated by DIP switch 1.

Amplifier The amplifier with variable gain has over 50 kHz bandwidth. At the side wall of the instrument a potentiometer for transducer sensitivity fine tuning can be found. The adjustable range is 10 to 100 mV/g. The M12 has 3 gain ranges which can be selected by the DIP switches nos. 2, 3 and 4 at the side wall as shown in the following table:

	Vibration acceleration	Vibration velocity	Vibration displacement
DIP 2	10 m/s ²	10 mm/s	100 μm
DIP 3	50 m/s ²	50 mm/s	500 μm
DIP 4	250 m/s ²	250 mm/s	2500 μm

Filters	The M12 contains separate high pass and low pass filters. These filters are designed as plug-in modules. Thus they can be replaced on site if necessary. The high pass filter has two poles with an attenuation of about 40 dB/decade. The low pass filter has four poles with about 70 dB/decade attenuation.
Integrators	For measuring vibration acceleration the M12 is used without integrators. When vibration velocity is measured, one integrator is in the signal path. Vibration displacement requires double integration. The integrators are switched on or off by the DIP switches nos. 5 to 7.
RMS Rectification	The instrument features a circuit for calculating true RMS with an integrating time of 1 s. The true RMS value ensures high accuracy independently of the signal shape. The RMS output is available via a 0 to 10 VDC output for external processing.
Peak-to-Peak Rectification	Additionally, the peak-to-peak value of the selected vibration quantity is measured. A true peak-to-peak rectifier ensures high accuracy independently of the signal shape. Positive and negative half waves are rectified separately, added and stored with a time constant of 1 s. The peak-to-peak output is available via a 0 to 10 VDC output for external processing.
DC Outputs	Both RMS and peak-to-peak values are available simultaneously at two separate outputs. Only one of these signals, however, can be used for controlling the relay and the 4-20 mA output. The monitoring mode is selected by the DIP switches no. 8 (RMS) and 9 (Peak-to-peak).
4-20 mA Loop Output	The RMS or peak-to-peak value of the selected vibration quantity is available as 4-20 mA current loop signal. This current loop output allows the transmission of analog signals over long distances with inexpensive cables. At the destination the pre-processed vibration signal can be fed into PLCs, panel meters, recorders or other 4-20 mA equipment. A side effect of long distance signal transmission can be ground loops. The accuracy of the M12 will not be affected by this phenomenon since the current loop output is optically insulated from the rest of the circuit.
Alarm Relay	In addition to its analog outputs, the M12 features a relay output which can be used to trigger external events when the adjusted threshold is exceeded. Possible devices to be connected are, for instance, contactors, alarm signals or binary inputs of a PLC. The relay output has a potential-free "Form C" contact. An "Alarm" LED indicates that the relay has responded. Both alarm threshold and delay (t_d) can be adjusted at the front panel. The adjustable delay range is 0 to 25 seconds. The relay hold time can be selected between two and eight seconds by means of DIP switch no. 10.

Figure 2 illustrates how the alarm management works.

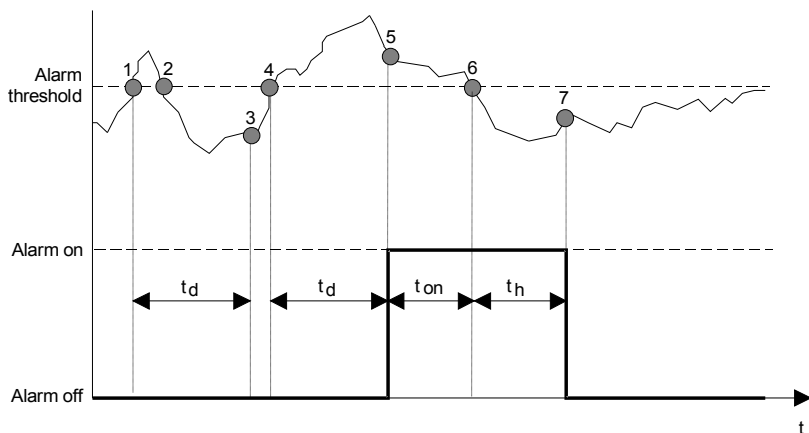

Figure 2: Alarm management

The upper curve of the diagram represents a typical vibration signal over time. It can be RMS or peak-to-peak signals. The lower curve shows the relay response.

At point ① the adjusted threshold was exceeded. Now the delay time t_d starts. It can be adjusted at the front panel between 0 and 25 s. Since the signal drops below the threshold at point ② before the delay time was over, no alarm will be tripped at point ③. By selecting an appropriate delay time is guaranteed that no alarm will be tripped by short signal transients. They may occur during machine start up or under the influence of a short mechanical shock pulse. At point ④ the alarm threshold is exceeded again and the delay time starts for the second time. Now an alarm will be tripped since after t_d at point ⑤ the alarm threshold is still exceeded. The relay remains active until the vibration level drops below the limit at ⑥. Now the alarm hold time t_h begins. It can be selected by DIP switch no. 10 between 2 and 8 seconds. When this hold time is over at point ⑦ the relay switches back. The purpose of a pre-selected hold time is to ensure save switching of external components.

Level Display

The bar graph display at the front panel has two functions. On one hand, it shows the current RMS or peak-to-peak value of the selected vibration quantity between 10 and 100 % of the full-scale value. On the other, it shows the relay threshold which can be adjusted by the potentiometer below.

The LED display gives comprehensible information about the current status of the vibration monitor.

Please note also the optionally available display module M12DIS (see section 4.4).

Self Test Functions

It is expected that monitoring equipment should have a very high reliability. Unnoticed faults need to be avoided and false alarms as well. Maximum reliability of the M12 is guaranteed by a two-stage self-test circuitry:

Monitoring of sensor bias voltage recognizes defective accelerometers and broken cables. When a defective sensor is detected, the “OK” LED is switched off and the alarm relay becomes active.

Power supply failure also causes the relay contact to switch into the alarm position.

AC Output

In addition to the DC outputs, the M12 also provides a “raw” vibration signal. By means of Jumper 1 a selection can be made between the buffered and unfiltered sensor signal or the amplified, filtered and, if selected, integrated signal (see Figure 1).

In the first case, the AC output provides the sensor signal with a bandwidth of over 50 kHz. Please note that most standard accelerometers have their resonance at 20 to 30 kHz.

In the second case, the AC signal is pre-processed in accordance with the selected vibration quantity and the inserted filters.

Overload Indication

An LED “OVL” is located at the front panel. It signals an overload condition before the filters, after the amplifier and after the integrators. If the LED starts flashing, the measuring signal will still be undistorted but it reaches its limits at ± 10 V.

Power Supply

The M12 needs for operation a DC supply voltage of 12 to 28 V. Its current consumption is between 80 and 200 mA. The lower the supply voltage, the higher the supply current.

Triple Insulation

Optimum protection against grounding problems is achieved by triple insulation between supply voltage, signal path and current loop output.

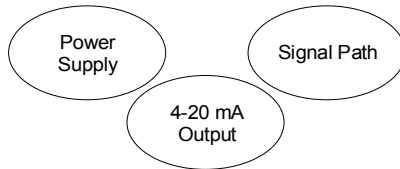

Figure 3: Triple Insulation

4. Installation

4.1. Preparing Measuring Points

Sensor Location

Before making measurements, suitable measuring points on the machine need to be found. Experience in machine condition maintenance is advantageous for selecting optimum spots.

Dynamic forces are normally transmitted via bearings and their housings into the machine frame. Therefore, bearing housings or points close to bearings are recommended as measuring points. Less suitable are light or flexible machine parts (Figure 4).

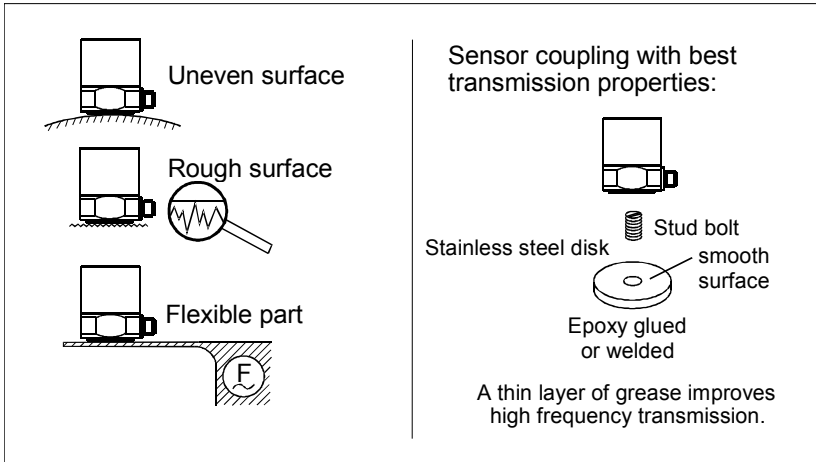

Figure 4: Recommendations for sensor mounting



An even and smooth surface at the mounting point is indispensable for precise vibration transmission from the machine to the accelerometer. Measuring points that are uneven, scratched or insufficiently sized may cause considerable errors, particularly at frequencies above 1 kHz.

For best coupling conditions, we recommend a stainless steel disk with mounting thread (for instance Metra Model 229) which can be epoxy glued or welded onto the machine.

The accelerometer is usually mounted by stud bolts. A thin layer of grease will improve high frequency transmission. For temporary installations a magnetic base can also be useful (for instance Metra Model 008).

ISO 10816-1

The standard ISO 10816-1 recommends that vibration measurements on machines be made at the housing of bearings or nearby measuring points.

For routine monitoring it is sufficient in many cases to measure vibration either in vertical or in horizontal direction. Rigidly mounted machines with horizontal shafts have their highest vibration levels mostly in a horizontal direction. Flexibly mounted machines may have high vertical components of vibration, too.

For inspections, vibration should be measured in all three directions (vertical, horizontal and axial) at all bearings.

The following illustrations show some examples for suitable measuring points.

You will also find recommendations for measuring points at different types of machines in ISO 13373-1.

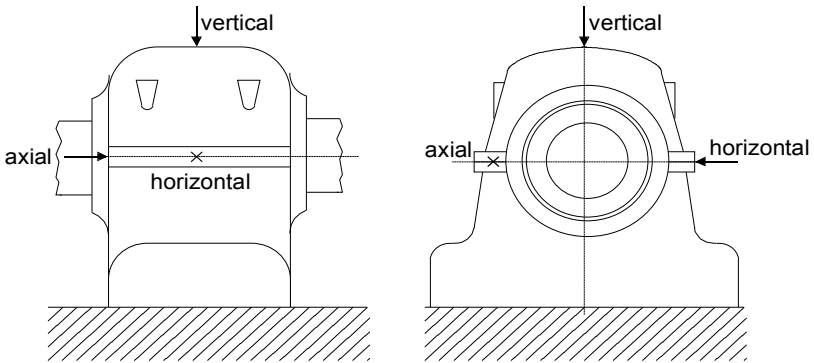

Figure 5: Measuring points on pillow block bearings

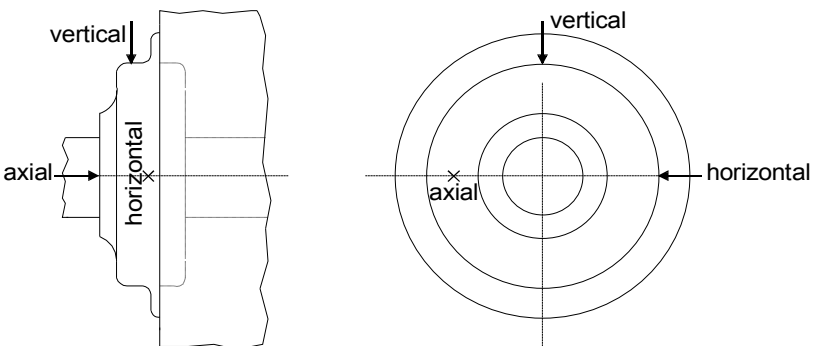

Figure 6: Measuring points on end shield bearings

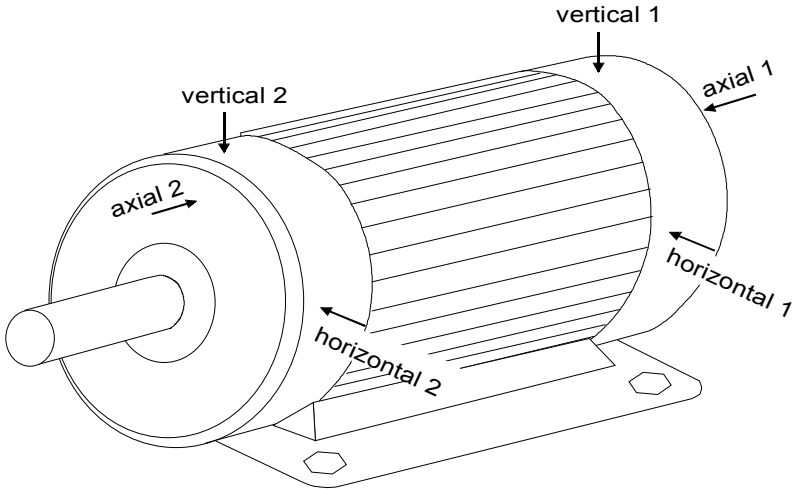

Figure 7: Measuring points on electric motors

4.2. Installation and Adjustment

4.2.1. Attachment

The M12 is designed for 35 mm DIN rails which are mounted horizontally. It should be installed in a dry and dust protected environment, preferably in switch cabinets.

To attach or release a module pull out the black lever on the top of the enclosure using a screw driver as shown in Figure 8.

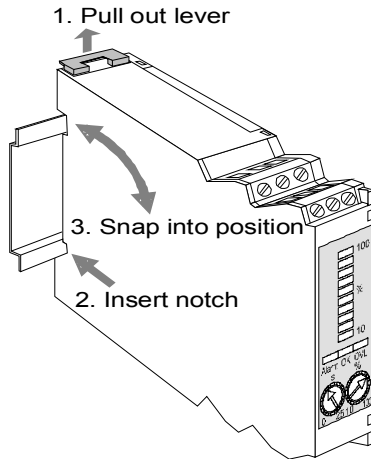

Figure 8: DIN rail attachment

☞ Make sure that there is at least 4 cm clearance above and under the case in order to allow ventilation. The power dissipation of each M12 is approx. 2.5 W.

The ambient temperature must not exceed 55 °C. In some cases artificial ventilation may be necessary.

Terminals

☞ Before attaching the case to the DIN rail, check that the following settings have been done:

Filter settings: Chapter 4.2.6, Page 20;

AC output settings: Chapter, 4.2.10, Page 26.

4.2.2. Power Supply

The M12 requires for operation a DC supply voltage between 12 and 28 V which is usually available in switch cabinets. Well suited are industrial 24 VDC power supplies for DIN rail attachment. The current consumption is between 80 and 200 mA, depending on the supply voltage. Figure 9 shows the connections. The M12 is protected against false polarization and short overvoltage transients. The power supply is insulated from the signal path.

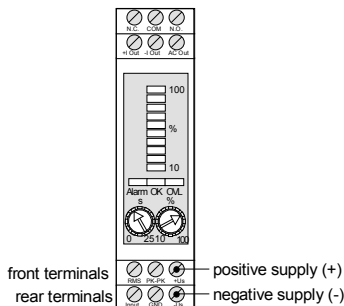

Figure 9: Power supply connection

4.2.3. Sensor

Sensor Input

The M12 is suitable for all kinds of IEPE accelerometers. The built-in constant current supply provides 4 mA supply current. A compliance voltage of 24VDC ensures full dynamic input range independent of the sensor bias voltage. The constant current source is activated by pushing the DIP switch no. 1 “IEPE Supply” towards the “ON” position (Figure 10).

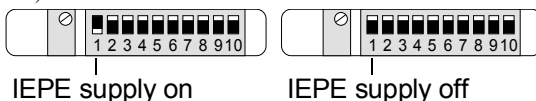

Figure 10: Activation of sensor supply

Sensitivity Adjustment

The M12 is suited for IEPE compatible accelerometers with sensitivities between 10 and 100 mV/g or 1 to 10 mV/ms⁻², respectively. The instrument is supplied pre-calibrated for transducers with a sensitivity of 100 mV/g. If sensors with other sensitivities are used, the M12 must be re-calibrated (see chapter 4.3, Page 29).



Please make sure that the constant current source (IEPE supply, DIP switch no. 1) is switched on.

The input is protected against overvoltage transients which may occur when the sensor is exposed to mechanical shock.



Ground loops may cause considerable measuring errors. To avoid these problems, preferably accelerometers with insulated base or with insulating flanges should be used. The ground potentials of the machine and the M12 are thereby separated.

Sensor Status Indication

The M12 can detect sensor faults. This is achieved by monitoring the bias voltage at the sensor output. Normal sensor operation is indicated by the LED “OK”. The LED is switched off and the relay switches to the alarm position when the bias voltage exceeds 20 VDC. In this case the constant current source is not able to drive sufficient current through the sensor circuit. Possible reasons may be a broken sensor cable, a loose plug or a defective sensor. Another reason might also be an extreme overload condition at the sensor output.

Figure 11 illustrates the sensor bias voltage and the limits of the dynamic range.

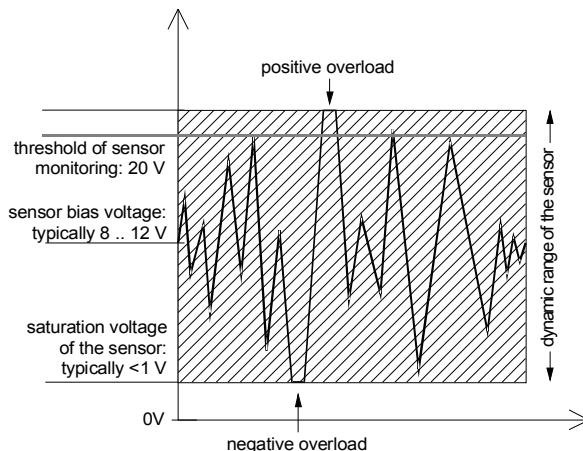

Figure 11: Dynamic range and bias voltage of IEPE sensors

Sensor Connection

The accelerometer is connected via coaxial cable or multi-wire shielded cables. Cables of several hundred meters length are permissible. Limitations are cable resistance and electromagnetic immunity.

The connection of the sensor is shown in Figure 12.

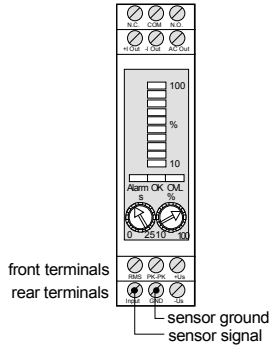

Figure 12: Sensor connection



Important: Make sure not to criss-cross sensor ground and sensor signal. This will immediately destroy the electronic circuit inside the sensor. Please contact the sensor manufacturer if you are not sure about the cable assignment.

Operation of Two M12 Modules with One Sensor

Two M12 modules can be operated with one mutual sensor. In this way many useful applications are possible. Figure 13 shows, for example, a combination for monitoring vibration velocity and acceleration with one sensor. It can be used to measure unbalance and bearing noise simultaneously.

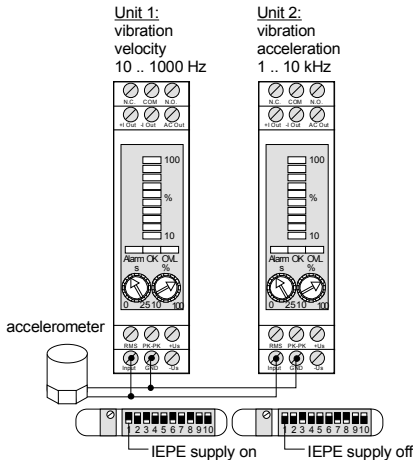

Figure 13: Monitoring vibration velocity and acceleration with one sensor

Figure 14 shows an example for monitoring vibration velocity to ISO 10816 with 2 alarm levels. By 2 different alarm settings pre-alarm and main alarm can be triggered.

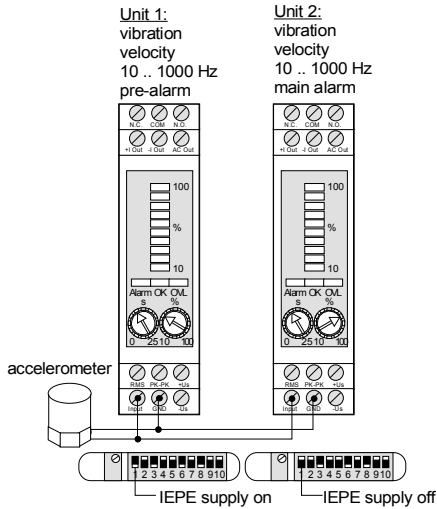

Figure 14: Monitoring system with 2 alarm levels



Please note that only one constant current source (IEPE supply, DIP switch no. 1) must be switched on when operating two M12 modules with the same sensor (compare Figure 13 and Figure 14).

Nevertheless the sensor status indication will work normally in both M12 units.

4.2.4. Selecting a Vibration Quantity

The M12 is capable of monitoring vibration acceleration, velocity and displacement, corresponding to no integration, single integration and double integration. RMS and peak-to-peak rectification are available for each vibration quantity. During installation the required quantity must be selected by the DIP switches at the side wall of the case. These adjustments have effect on the relay output, the 4-20 mA output and the bar graph display.

The vibration quantities (or integrators) are selected by pushing down one of the DIP switches nos. 5 to 7 as shown in Figure 15.

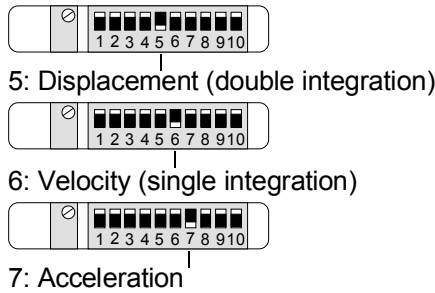

Figure 15: Selecting the vibration quantity

Dynamic Range of the Integrators

A typical property of integrators is that the output voltage decreases with increasing frequency. When one or both integrators are switched on, the dynamic range of the M12 will decrease rapidly at frequencies of a few hundred Hertz (Figure 16). If double integration is selected, for example, the dynamic range at 160 Hz will become only 10 % of full scale. Instead of 2500 μm the maximum displacement to be measured will be only 250 μm , consequently. Therefore, the use of integrators usually makes sense only at lower frequencies. Vibration signals with frequencies in the Kilohertz range should always be measured as acceleration.

For very low frequencies the integrators provide high output levels. Low frequency noise, which may originate from the sensor or the amplifier circuit, will be amplified by the integrators. It is recommended therefore to insert a high pass filter of 3 Hz or more when the integrators are used.

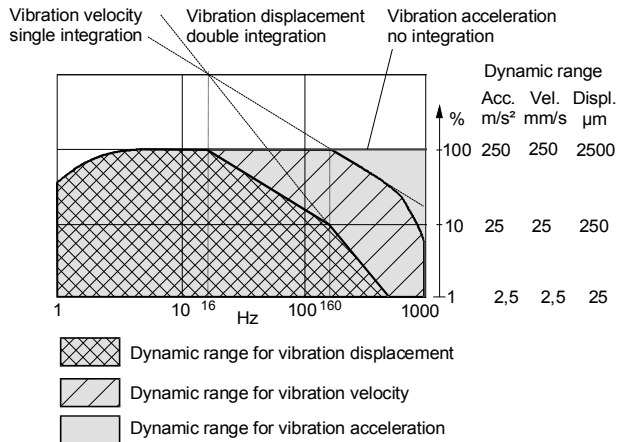

Figure 16: Dynamic range of the integrators

**RMS /
Peak-to-Peak**

By means of the DIP switches nos. 8 and 9 a selection can be made between RMS and peak-to-peak rectification.



8: RMS detection

9: peak-to-peak detection

Figure 17: Selecting the rectification mode



Only one of the DIP switches 8 and 9 must be switched on.

4.2.5. Selecting the Measuring Range

The instrument features three measuring ranges. They are selected by the DIP switches nos. 2, 3 and 4. Push the switch lever for the desired range downwards. The following table shows the measuring ranges for each vibration quantity.

DIP Switch	Vibration Acceleration (no integration)	Vibration Velocity (single integration)	Vibration Displacement (double integration)
2	10 m/s ²	10 mm/s	100 μm
3	50 m/s ²	50 mm/s	500 μm
4	250 m/s ²	250 mm/s	2500 μm



Only one of the DIP switches 2, 3 and 4 must be switched on.

The full-scale values in the above table are reached with both RMS and peak-to-peak rectification. The measuring ranges are only valid under the condition that the VM12 was calibrated with its accelerometer (compare chapter 4.3, page 29).

**Overload
Indication**

If the LED “OVL” lights up the measuring range should be increased. An overload indication does not necessarily mean that the RMS or peak-to-peak outputs are overloaded. In some cases the reason may be a dominant frequency component beyond the filter pass band which does not appear at the output but which overloads the amplifier. This can be checked at the AC output provided jumper J1 is in position 1-2.

4.2.6.Plug-in Filters

The M12's replaceable filters make it particularly versatile. They can be configured on site depending on the vibration signal.

The M12 has two 8 pin sockets for a high pass and a low pass filter module. These filter modules are available as accessories. Metra offers the following versions:

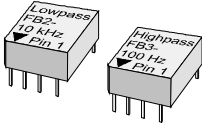

Low pass plug-in filter Model FB2: 0,1 kHz; 0,3 kHz; 0,5 kHz; 1 kHz; 3 kHz; 5 kHz; 10 kHz; 30 kHz kHz

High pass plug-in filter Model FB3: 2 Hz; 3 Hz; 5 Hz; 10 Hz; 30 Hz; 50 Hz; 100 Hz; 300 Hz; 500 Hz; 1000 Hz

Filters with other frequencies can be supplied on demand.

Slope

The low pass filters of FB2 series have 4th order Butterworth characteristics with a slope of about 70 dB/decade.

The high pass filters of FB2 series are 2nd order filters with about 40 dB/decade attenuation.

Factory Configuration

The M12 is supplied with the filter modules as desired by the customer. The cut-off frequencies of the built in filters can be found on the M12 label.

Replacing Filter Modules

To insert or replace a filter module the case has to be opened. The lid is removed, as shown in Figure 18, by opening 6 snap tabs using a screw driver.

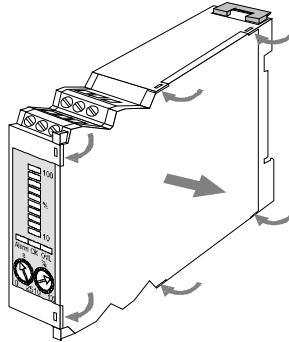

Figure 18: Opening the case

After removing the lid, the back of the PCB becomes visible. Pull out the PCB carefully. The main PCB is connected via a ribbon cable with the front PCB. Prevent the front PCB from sliding out with your finger. Put the main PCB beside the case with its components facing towards you.



Caution: Electrostatic discharge may damage the electronic circuit. Carefully discharge your hands and any tools before touching the PCB.

The location of the filter modules can be seen in Figure 19. Please make sure that the marking “Pin 1” on the filter is in the same position as the marking on the PCB.

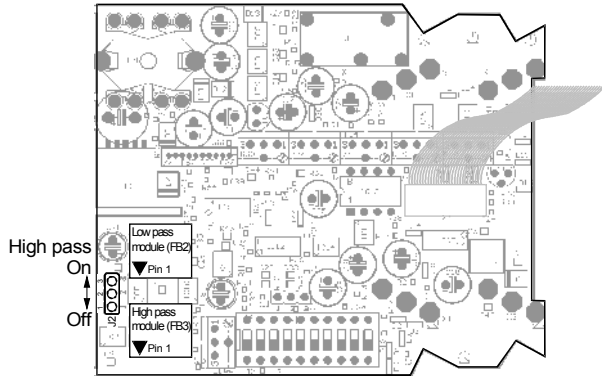

Figure 19: Location of the filters on the PCB



The low pass filter is necessary for operation of the M12. The high pass filter can be omitted when a lower frequency limit of 1 Hz is desired. If no high pass filter module is plugged in, jumper J2 has to be in position “Off” (1-2) as shown in Figure 19.

4.2.7. Relay Output

Adjustments

The M12 features a relay output with “Form C” contact. It can be used for alarm tripping when a pre-adjusted limit is exceeded. The switch behavior of the relay is shown in Figure 2 in chapter 3. An alarm tripping is indicated at the front panel by the LED “Alarm”.

Alarm threshold and delay time are adjusted by two knobs at the front panel (Figure 20). The adjustable range for the delay time is from 0 s (immediate tripping) to a maximum of 25 s. The threshold between 10 and 100 % of the measuring range can be chosen. The bar graph display shows the adjusted alarm threshold.

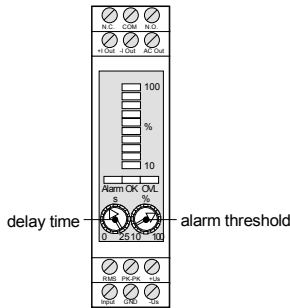

Figure 20: Adjustment of alarm threshold and delay time

The alarm duration (hold time) can be chosen by DIP switch no. 10 between 2 s (short) and 8 s (long) as shown in Figure 21.

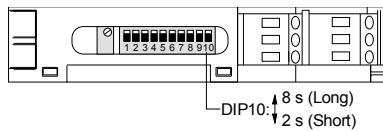

Figure 21: Alarm duration

Connection of the Relay Output

Figure 22 shows the relay terminals. In alarm condition terminals 1 and 2 are shorted. Under normal operation terminals 2 and 3 are shorted.

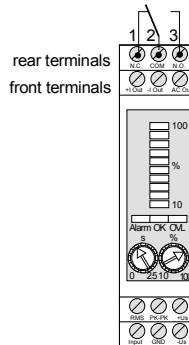

Figure 22: Relay output, contacts shown in alarm condition

Self Test Function

If no alarm is tripped, the relay coil is current-carrying. In the alarm condition the coil is currentless. Therefore, a failure of the power supply voltage will cause the relay to switch into alarm position. In this way the power supply of the M12 is monitored.

Sensor Monitoring

Please note that a sensor failure will also cause the relay to give an alarm message (compare chapter 4.2.3).

Contact Rating The relay contacts are insulated from the circuit of the M12. They can carry up to 2 A at 40 VAC. If several M12 modules are in use, the relay outputs can be grouped by series connection (AND function) or parallel connection (OR function).

4.2.8. Current Loop 4-20 mA Output

In addition to the relay output the M12 features a 4-20 mA current loop output. Current loop signals can be advantageous for long distance transmission over several kilometers. The 4-20 mA output provides the vibration signal as selected by the DIP switches (see chapter 4.2.4). It can represent the RMS or peak-to-peak value depending on the positions of DIP switches 8 and 9. The maximum current of 20 mA corresponds to 100 % of the measuring range or the upper LED of the bar graph display.

The corresponding vibration level (V) of an output current can be calculated by:

$$V = \frac{MR \cdot (I - 4 \text{ mA})}{16 \text{ mA}}$$

where MR is the selected measuring range.

For example a loop current of $I_{\text{LOOP}} = 8 \text{ mA}$ and a measuring range of 200 mm/s (peak-to-peak) come to a vibration velocity of:

$$V = \frac{10 \text{ mm/s}_{\text{pk-pk}} \cdot (8 \text{ mA} - 4 \text{ mA})}{16 \text{ mA}} = 2,5 \text{ mm/s}_{\text{pk-pk}}$$

The 4-20 mA output acts as a current drain. Therefore, a voltage supply is required in the loop circuit. Figure 23 shows the loop principle. The loop output of the M12 needs a minimum voltage of 12 VDC over the terminals $+I_{\text{OUT}}$ and $-I_{\text{OUT}}$. Hence the voltage source (U_s) has to be designed as follows:

$$U_s > 12 \text{ V} + U_L$$

U_L is the voltage drop over all resistors in the loop including cable resistance at 20 mA.

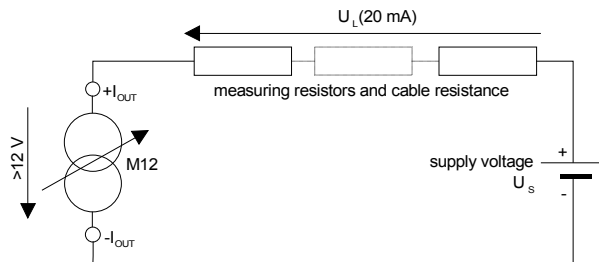

Figure 23: 4-20 mA loop circuit

Often the 24 VDC supply voltage of the M12 is also used as loop supply.



The voltage at the terminals $+I_{OUT}$ and $-I_{OUT}$ must not exceed 30 VDC.

Connection

Figure 24 shows the terminals of the 4-20 mA output

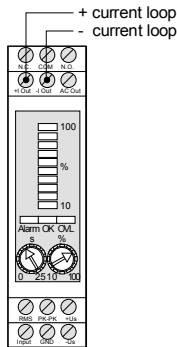

Figure 24: 4-20 mA current loop connection

Insulation

Insulation of the current loop output is provided by an opto coupler. Thus potential differences, as they often occur in large cable networks, will not affect the accuracy of the M12.

False

Polarization

The 4-20 mA output is protected against false polarization of the loop supply voltage

4.2.9.DC Outputs

The M12 features two DC outputs for the RMS and the peak-to-peak values of the selected vibration quantity (Figure 25). Both outputs are referred to GND. Their voltage range is 0 to +10 V.

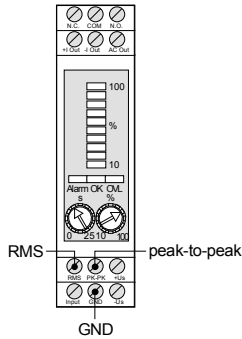

Figure 25: DC outputs

The RMS detection has an integration time constant of approximately 1 second.

The hold time of the peak-to-peak output is also 1 second.



Please note that the peak-to-peak output will already be overloaded when the RMS output voltage exceeds 10 V.

4.2.10.AC Output

In addition to the RMS and peak-to-peak outputs, it is often desirable to measure the unrectified accelerometer signal. By means of external equipment like analyzers or scopes an experienced maintenance engineer can acquire additional information about the source of vibrations. This analysis can be performed either on site, or, after storing the analog signal on a data logger, at another place. For connecting such equipment the M12 features an AC output.

Filtering and Integration

The AC output can deliver two kinds of signals:

- Raw signal of the transducer: In this mode the AC output provides the unfiltered but amplified acceleration signal.
- Filtered / integrated: In this mode the AC output signal is pre-processed depending on the selected monitoring quantity. Hence the AC signal can be filtered and, if vibration velocity or displacement are selected, integrated.

Settings

The AC output mode is selected by jumper J1. You will find it after removing the lid from the case. This can be done by opening six snap tabs using a screw driver as shown in Figure 26.

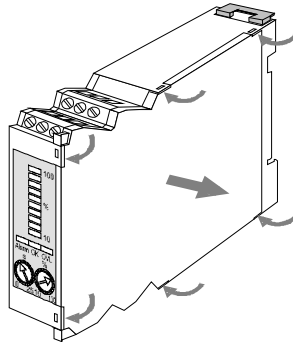

Figure 26: Opening the case

After removing the lid the back of the PCB becomes visible. Pull out the PCB carefully. The main PCB is connected via a ribbon cable with the front PCB. Prevent the front PCB from sliding out with your finger. Put the main PCB beside the case with its components facing towards you.



Caution: Electrostatic discharge may damage the electronic circuit. Carefully discharge your hands and any tools before touching the PCB.

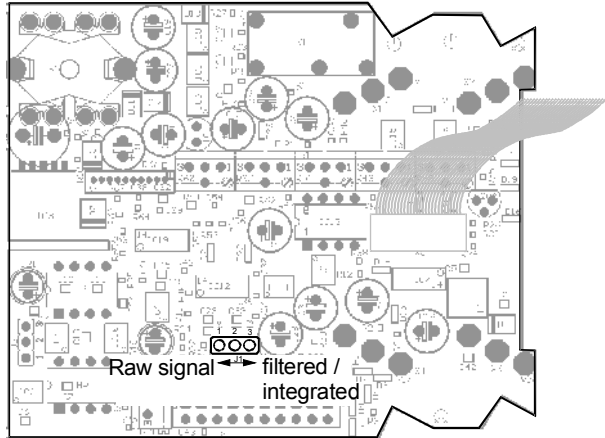

Figure 27: Setting the AC output mode by jumper J1

Figure 27 shows the position of jumper J1. In its left position (1-2 closed) the AC output provides the unfiltered sensor signal. In the right position (2-3 closed) the AC output provides the filtered and integrated signal.

Output Level

The AC output voltage depends on the selected measuring range (compare chapter 4.2.5) and the calibrated transducer sensitivity. The following table shows the output sensitivity for all measuring ranges and integrator options provided the M12 has been calibrated with its accelerometer (compare chapter 4.3, page 29).

Measuring range	AC Output
10 m/s ² (no integrator)	500 mV/ms ⁻²
10 mm/s (single integration)	500 mV/mms ⁻¹
100 μm (double integration)	50 mV/μm
50 m/s ² (no integrator)	100 mV/ms ⁻²
50 mm/s (single integration)	100 mV/mms ⁻¹
500 μm (double integration)	10 mV/μm
250 m/s ² (no integrator)	20 mV/ms ⁻²
250 mm/s (single integration)	20 mV/mms ⁻¹
2500 μm (double integration)	2 mV/μm

The sensitivity at the AC output is half the sensitivity of the DC outputs (RMS and peak-to-peak). For example, 10 VDC at the RMS output correspond to $5 V_{\text{RMS}}$ at the AC output or 10 VDC at the peak-to-peak output correspond to $5 V_{\text{PK-PK}}$ at the AC output.

The dynamic range of the AC output is ± 10 V.

Bandwidth

The AC output is DC coupled with a serial resistance of 100Ω . In the unfiltered mode (J1 in position 1-2) its bandwidth is 1 Hz to > 30 kHz. Please note that most industrial accelerometers have their natural resonance at 20 to 30 kHz.

In the filtered mode (J1 in position 2-3) the bandwidth depends on the used filters and the integrators.

Connection

Figure 28 shows how the AC output is connected. The output signal is referred to GND. The cable length at the AC output must not exceed 5 to 10 m.

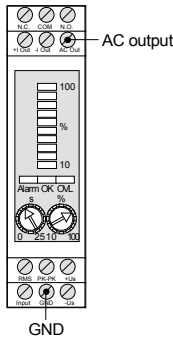

Figure 28: AC output

4.3. Calibration

Factory Calibration

Metra supplies the M12 calibrated with its sensor if the instrument is ordered together with a Metra accelerometer. If the M12 is ordered without transducer its default sensitivity calibration will be 100 mV/g.



Factory calibration is only valid with unaltered transducer sensitivity adjustment.

Calibration Point

The calibration potentiometer for transducer sensitivity can be found next to the DIP switches. At the left stop the sensitivity is about 100 mV/g (10 mV/ms^{-2}), at the right stop it is about 10 mV/g (1 mV/ms^{-2}). The potentiometer has 25 turns.

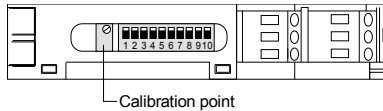

Figure 29: Calibration of transducer sensitivity

Vibration Calibrator

If the plugged-in filter modules are linear at 160 Hz calibration can be performed using a Vibration Calibrator of Metra's VC series. It provides a stabilized vibration signal of 10 m/s^2 , 10 mm/s and $10 \mu\text{m}$ at a frequency of 160 Hz. This signal can be used to excite the accelerometer and to calibrate the M12 in mechanical units.

Electrical Calibration

Otherwise the M12 may be calibrated by feeding in an electric signal instead of the accelerometer signal. The generator signal to be fed in depends on the sensitivity of the accelerometer. If the sensitivity given in the accelerometer data sheet is, for example, 2.53 mV/ms^{-2} , a generator magnitude of 253 mV is necessary to simulate an acceleration of 100 m/s^2 . Choose the calibration frequency in the middle of the filter pass band.

If the M12 is used for monitoring vibration velocity or displacement, it can be calibrated in the acceleration range and afterwards the integrators can be switched on.

4.4.Vibration Level Display M12DIS

A useful option for the M12 is the display module M12DIS. It turns the M12 monitor into a vibration meter. Depending on the M12 settings it will display RMS or peak-to-peak values of vibration acceleration, velocity or displacement. Model M12DIS is a 3½ digit LCD for connection to the M12 current loop output. The unit is loop powered. No additional power supply is required except for the LED backlighting.

Connection

The display unit is connected to the 4-20 mA output of the M12 and the loop power supply according to chapter 4.2.8. The terminals I+ and I- of the display are used for connection. The maximum voltage drop across these display terminals is 6 V. Further 4-20 mA instruments can be switched in series with the display provided the loop supply voltage is high enough to produce a voltage drop of 12 V across the M12 loop terminals. The 24 VDC supply voltage of the M12 may also be used as loop supply.

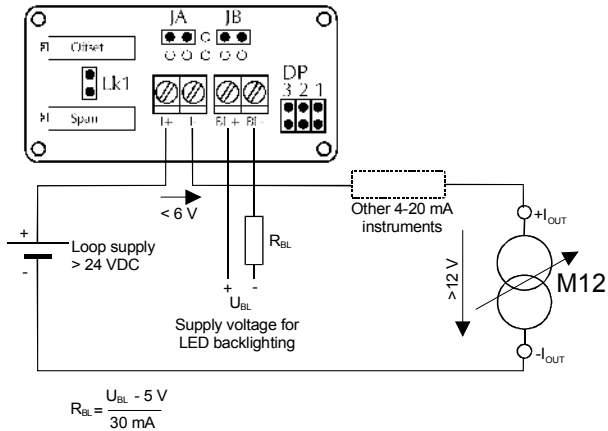

Figure 30: Connection of the display

LED Backlighting

If desired, an LED backlighting can be activated by means of an additional DC supply voltage. It must be connected to the terminals BL+ and BL- via a current limiting resistor R_{BL} as shown in Figure 30. The current consumption of the backlighting is 30 mA.

The resistor is calculated as follows:

$$R_{BL} = \frac{U_{BL} - 5 V}{30 \text{ mA}}$$

The resistor R_{BL} is not necessary if the supply voltage U_{BL} is $5 V \pm 0.25 V$.

Mounting

The display module is suitable for the attachment at front panels, switch boards, switch cabinet doors and other flat objects. For this purpose a mounting bezel is supplied with the M12DIS. The following pictures show the dimensions of the cut out and how the display is mounted.

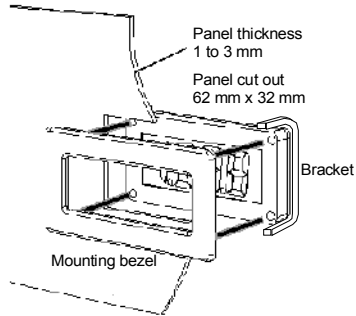

Figure 31: Panel cut out

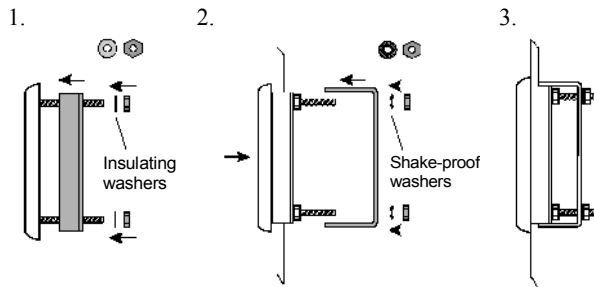

Figure 32: Display mounting

Calibration

If not ordered otherwise, the M12DIS is supplied factory calibrated to display “0” at 4 mA and “1000” at 20 mA. For recalibration the potentiometers “Offset” (Zero) and “Span” (full scale) are used.

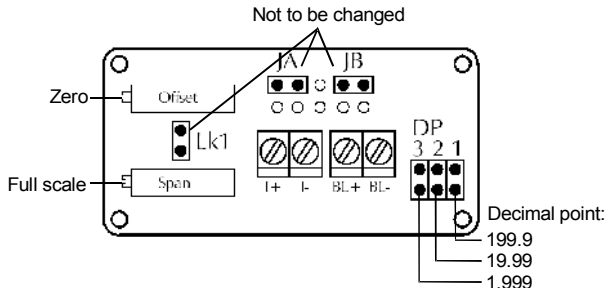

Figure 33: Calibration points

Calibration of the M12DIS is carried out either directly by an adjustable 4-20-mA constant current source or together with the M12. For calibration with the M12 a vibration reference signal is fed into the accelerometer or a generator signal is applied to the M12 input as explained in chapter 4.3. Preferably a vibration calibrator should be used to eliminate errors by calibration of the entire measuring chain.

The M12 must be calibrated before calibrating the display. The measuring range of the M12 must be selected so that the calibration signal provides at least 50 % of the full-scale level, for instance, use the range “10” if the calibration level is 10 mm/s.

After applying the calibration signal, adjust the display to the reference level, for instance “1000” for 10 mm/s, using the potentiometer “Span”.

Switch off the calibration signal and adjust the zero display using the potentiometer “Offset”.

Repeat the calibration of span and offset alternately a few times until both settings are correct.

Finally the position of the decimal point is set by means of jumper DP1, DP2 and DP3.

5.Measuring Methods for Machine Vibration

Permanent vibration monitoring as part of a predictive maintenance program allows for the prediction of breakdown of machines and will thereby save maintenance cost.

The assessment of machine vibrations requires a high degree of experience. This chapter introduces briefly some proven methods.

5.1.Vibration Severity Measurement for Unbalance

A widespread procedure for monitoring the unbalance of rotating machines is to measure vibration velocity (sometimes also called vibration severity). Vibration severity is a measure of energy of the emitted vibration. Reasons for unbalance may be, for instance, loose screws, bent components, worn out bearings with too much clearance or dirt on blower fans. Often several of these effects can influence one another.

ISO 10816-1

If no reference values of vibration severity are available on the relevant machine, you may refer to the recommendations of ISO 10816-1 (see table below). Here you will find permissible values of the vibration severity of different machine types. The basis of the assessment is the maximum value of all measured points on the machine.

Machine Type	Power Rating or Shaft Height	Speed min ⁻¹	Foundation	Max. Continuous value mm/s
Steam Turbines	300 kW – 50 MW		rigid	7.1
	300 kW – 50 MW		flexible	11
	> 50 MW	< 1500	rigid	7.1
	> 50 MW	< 1500	flexible	11
	> 50 MW	1500 – 1800		8.5
	> 50 MW	3000 – 3600		11.8
	> 50 MW	> 3600	rigid	7.1
Electrical Engines	< 160 mm		rigid	2.8
	< 160 mm		flexible	4.5
	160 – 315 mm		rigid	4.5
	160 – 315 mm		flexible	7.1
	> 315 mm	120 – 15000	rigid	7.1
Gas Turbines	> 315 mm	120 – 15000	flexible	11
	< 3 MW		rigid	7.1
	< 3 MW		flexible	11
Generators	> 3 MW	3000 – 20000		14.7
	> 50 MW	1500 – 1800		8.5
Blowers, Compressors	> 50 MW	3000 – 3600		11.8
	< 15 kW		rigid	2.8
	< 15 kW		flexible	4.5
	15 – 300 kW		rigid	4.5
	15 – 300 kW		flexible	7.1
	> 300 kW		rigid	7.1
Pumps with separate drive	> 300 kW		flexible	11
	< 15 kW		rigid	4.5
	< 15 kW		flexible	7.1
	> 15 kW		rigid	7.1
Pumps with integrated drive	> 15 kW		flexible	11
	< 15 kW		rigid	2.8
	< 15 kW		flexible	4.5
	> 15 kW		rigid	4.5
	> 15 kW		flexible	7.1

Measurement with the M12 Vibration severity to DIN/ISO 10816 can be measured with the M12 in a simple way. A 10 Hz high pass filter and a 1 kHz low pass filter are required. Vibration velocity is selected by DIP switch no. 6. RMS monitoring is activated by DIP switch no 8. The appropriate measuring range can be chosen by the DIP switches nos. 2, 3 and 4.

5.2.Vibration Measurement on Reciprocating Engines

DIN/ISO 10816-6

Reciprocating engines, like combustion engines and compressors, are characterized by backward and forward going masses. The vibration generated by this motion, is higher than the vibration of rotating machinery. Standard ISO 10816-6 contains recommendations for the assessment of vibrations of reciprocating machines. The measured quantities are the RMS values of acceleration, velocity and displacement. They are picked up at the machine block in all three axes of the room. The recommended frequency range reaches from 2 Hz up to 1000 Hz.

By means of the measured values of all three vibration quantities, the reciprocating engine may be classified as belonging to a particular class of assessment. The following table allows this classification. At first read the relevant vibration severity level for all three measured vibration quantities. The decisive class is the highest of these three determined severity classes. In the right part of the table you find the degree of machine condition in dependence on the machine class (depending on size, construction, assembly and speed of the machine).

Vibration Severity Level	Maximum Vibration			Machine Class						
	Vibration Displacem. μm RMS	Vibration Velocity mm/s RMS	Vibration Accelerat. m/s^2 RMS	1	2	3	4	5	6	7
1.1	< 17.8	< 1.12	<1.76	A/B	A/B	A/B	A/B	A/B	A/B	A/B
1.8	< 28.3	< 1.78	< 2.79							
2.8	< 44.8	< 2.82	< 4.42							
4.5	< 71.0	< 4.46	< 7.01							
7.1	< 113	< 7.07	< 11.1	C	D	D	D	D	D	D
11	< 178	< 11.1	< 17.6							
18	< 283	< 17.8	< 27.9							
28	< 448	< 28.2	< 44.2							
45	< 710	< 44.6	< 70.1	D	D	D	D	D	D	D
71	< 1125	< 70.7	< 111							
112	< 1784	< 112	< 176							
180	> 1784	> 112	> 176							

The assessment classes have the following meanings:

- A New machines
- B Continuous running without restriction possible
- C Not suitable for continuous running, reduced operability until the next scheduled maintenance
- D Too high vibration, damage to the machine cannot be excluded

Measurement with the M12

Monitoring reciprocating machines to DIN/ISO 10816-6 can be performed by 3 M12 modules and a mutual accelerometer. For each unit a 2 Hz high pass filter and a 1 kHz low pass filter are required. One M12 has to be adjusted for acceleration, the second one for velocity and the third for displacement. Select RMS rectification (DIP switch no. 8). The appropriate measuring range is chosen by the DIP switches nos. 2, 3 and 4. The measuring values can be processed as 4-20 mA or DC voltage signals.

5.3. Bearing Monitoring

General

The two methods to ISO 10816 described above are concerned with vibration caused by unbalanced masses. This section deals with vibration generated by roller bearings.

Typical reasons for damage to roller bearings are fatigue, corrosion, cage damage, insufficient lubrication or fatigue caused by excess strain. The results are damages of the ball race (creation of pittings), rising temperature, increasing noise, rising bearing clearance, flutter up to the breakage of the cage and total breakdown of the machine.

The movement of rolling elements along such damage, such as pittings, generates mechanical pulses which initiate vibrations of the whole bearing. These vibrations can be measured, for instance, at the housing of the bearing.

As a rule, the vibrations of roller bearings have frequencies above 1 kHz. Usually acceleration is measured.

Damage to roller bearings may be diagnosed either by frequency analysis or in the time domain by RMS and peak value measurements.

The diagnosis of the frequency spectrum provides the most detailed information about a bearing, but requires a high degree of experience.

Vibration measurement in time domain (measurement of RMS and peak value of acceleration) is much easier to perform but yields less specific results. In many cases, however, it is sufficient to evaluate the condition of a roller bearing.

Crest Factor

An established method in time domain is the measurement of the crest factor. The crest factor is the quotient of the peak value and the RMS of acceleration (\hat{a}/a_{rms}). This method is based on the experience that in the early pre-damage stage of the bearing the RMS of acceleration shows only small changes, whereas the peak value increases significantly (see Figure 34).

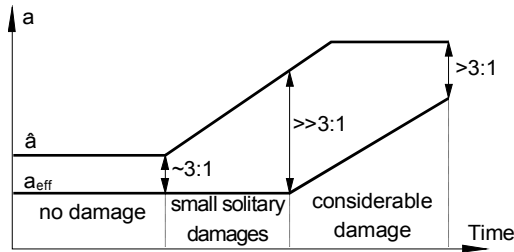

Figure 34: Typical development of roller bearing damages

The following table shows the crest factor and, alternatively, the product of peak and RMS values in dependence on the degree of bearing damage.

Condition	a_{eff}	\hat{a}	\hat{a}/a_{eff}	$\hat{a} \cdot a_{\text{eff}}$
no damage	small	small	~ 3	small
small individual damage	small	increased	>3	slightly increased
several individual damages	increased	increased	>3	medium increased
severe individual damage	increased	high	$\gg 3$	increased
many severe individual damages	high	high	>3	high

Diagnostic Coefficient

Another method of monitoring roller bearings in time domain is the diagnostic coefficient $D_K(t)$ according to Sturm. This coefficient is calculated from the RMS and the peak values of the acceleration at good operating condition of the bearing (initial values with the index 0) and at the present condition (index t):

$$D_K(t) = \frac{a_{\text{eff}}(0) \cdot \hat{a}(0)}{a_{\text{eff}}(t) \cdot \hat{a}(t)}$$

According to Sturm the following values represent the indicated conditions:

$D_K(t)$	Bearing Condition
> 1	Improvement
$1 - 0.5$	Good operating condition
$0.5 - 0.2$	Accelerating influence to the damaging process
$0.2 - 0.02$	Progressive damaging process
< 0.02	Damage

Measurement with the M12

The two described methods of bearing monitoring can be applied using one M12 module. A 1 kHz high pass and a 10 kHz low pass filter are required. The high pass filter suppresses unbalance vibrations and lets only bearing noise pass. The 10 kHz low pass is recommended for suppressing the resonance peak of the accelerometer. The M12 must be in the acceleration range. The DC outputs for RMS and peak-to-peak values

provide the relevant quantities. Multiplication and division have to be performed externally.



Please note that the M12 measures the peak-to-peak value. It has to be divided by 2 to obtain the peak value \hat{a} .

6. Technical Data

Measuring ranges

Vibration acceleration	10 / 50 / 250 m/s ²
Vibration velocity	10 / 50 / 250 mm/s
Vibration displacement	100 / 500 / 2500 μm

Accuracy (referred to full scale)

	RMS	peak-to-peak
Vibration acceleration	$\pm 5 \%$	$\pm 5 \%$
Vibration velocity	$\pm 5 \%$	$\pm 8 \%$
Vibration displacement	$\pm 8 \%$	$\pm 15 \%$

Input

voltage input, $R_1 = 1 \text{ M}\Omega$
AC coupled, IEPE compatible

Sensor supply

3.8 - 5.6 mA constant current
compliance voltage $> 24 \text{ V}$
selectable by DIP switch

Suitable sensors

IEPE compatible accelerometers
sensitivity: 1 - 10 mV/ms²

Frequency ranges

Wide band signal at AC output	1 Hz - $> 50 \text{ kHz}$ (-3 dB) without Filter
Vibration acceleration	1 Hz - 50 kHz (without high pass / 50 kHz low pass)
Vibration velocity	3 Hz - 1 kHz (with high pass)
Vibration displacement	3 Hz - 200 Hz (with high pass)

Band filter

High pass	plug-in high pass and low pass modules Butterworth, 2 nd order, 40 dB/decade
Low pass	Butterworth, 4 th order, 70 dB/decade

Rectification

true RMS, integration time constant approx. 1 s
true peak-to-peak value, hold time approx. 1 s

Relay output

Form C contact, 40 VAC / 2A

Adjustable relay threshold

10 - 100 % of measuring range, potentiometer

Adjustable relay delay

0 - 25 s $\pm 20 \%$, potentiometer

Relay hold time

selectable by DIP switch
short: approximately 2 s
long: 6 - 10 s

4-20 mA current loop output

passive, opto insulated
terminal voltage: 12 - 30 V

Wide band output	acceleration signal, $\hat{u}_a = \pm 10 \text{ V}$ 1 Hz - > 50 kHz, impedance: 500 Ω
DC outputs	0 - 10 V RMS 0 - 10 V peak-to-peak
Sensor status indication	LED („OK“) and alarm relay threshold: 20 V sensor bias voltage
Overload indication	LED („OVL“) at $\pm 10 \text{ V}$ amplifier output voltage
Level display	10 step LED bar graph 10 - 100 % of measuring range and display of alarm threshold
Power supply	12 - 28 VDC / 80 - 200 mA insulated from signal path
Operating temperature range	-20 - 55 $^{\circ}\text{C}$ rel. humidity < 95 %, no condensation
Dimensions (W x H x D)	22 x 76 x 111 mm ³
Weight	140 g

Limited Warranty

Metra warrants for a period of
24 months
that its products will be free from defects
in material or workmanship
and shall conform to the specifications
current at the time of shipment.

The warranty period starts with the date of invoice.
The customer must provide the dated bill of sale as evidence.
The warranty period ends after 24 months.

Repairs do not extend the warranty period.

This limited warranty covers only defects which arise as a result
of normal use according to the instruction manual.

Metra's responsibility under this warranty does not apply to any
improper or inadequate maintenance or modification
and operation outside the product's specifications.

Shipment to Metra will be paid by the customer.
The repaired or replaced product will be sent back at Metra's expense.



Declaration of Conformity

Product: Universal Vibration Monitor
Model: M12

It is hereby certified that
the above mentioned product
complies with the demands
pursuant to the following standards:

EN 50081-1
EN 50082-1

Responsible for this declaration is the producer

Manfred Weber
Metra Mess- und Frequenztechnik in Radebeul e.K.
Meißner Str. 58
D-01445 Radebeul

Declared by

Michael Weber
Radebeul, 2nd of January, 2007