

Wire Rope Overload Guard KSW-3R

Special Features

- Wire ropes diameters (Ø 10-38mm)
- Rope loads from 20kN to 320kN
- Environmental protection IP65
- Completely in stainless steel
- Standard signal output 4 – 20mA
- With mounting unit XKM 078
- Optional: impulse transmitter for measuring rope displacement



Foto: KSW 3-R with side plate dismounted

Dimensions

Wiring code

Cable to be connected to amplifier box, diameter 6 ... 12mm
Refer to datasheet BA 625 for more details

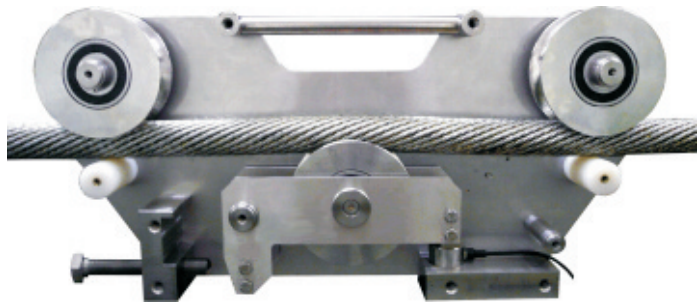
Dimensions with mounting unit XKM 078

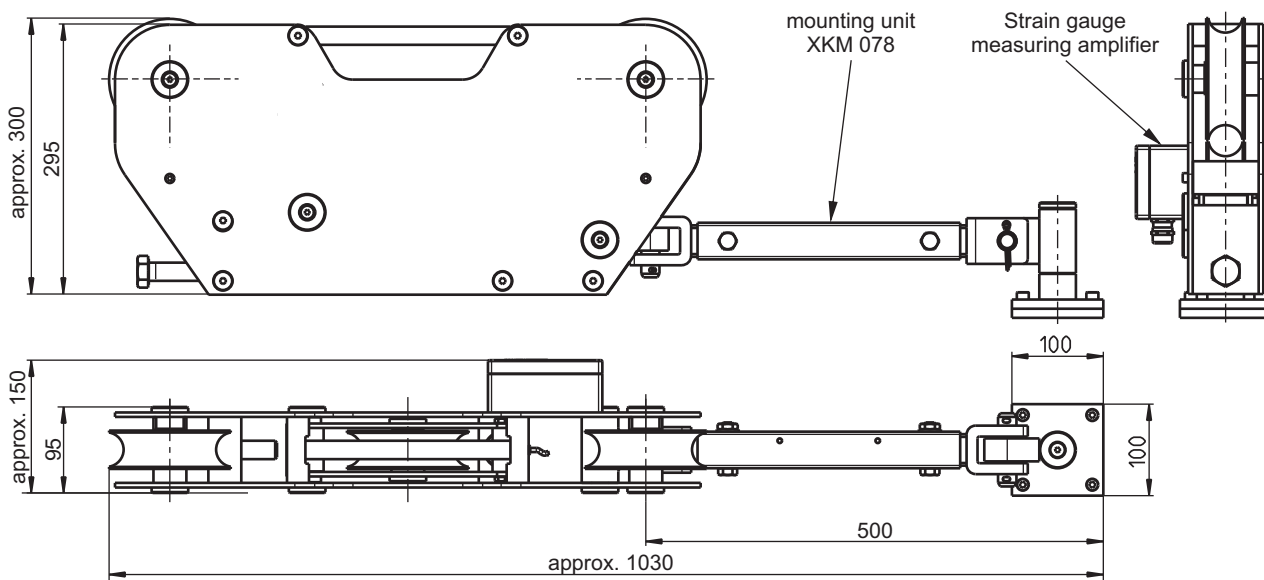

Accessories (included in delivery)

| Type code | Description |
|-----------|--|
| XKE 801 | Factory certificate / Test certificate |
| XKM 078 | mounting unit |

Wire Rope Overload Guard KSW-3R

Specifications

| | | |
|---|---|---|
| Reproducibility | % S | 0,2% internally for force sensor 1 % with resting rope 2 % after current rope or after rope change 3 % after sensor change |
| Wire ropes Range of rope diameter Rated load | mm kN | 10 ... 38 20 ... 320 |
| Strain gauge measuring amplifier BA 625 Signal output Max. burden Power supply Cable diameter Cable cross section | mA Ω VDC mm mm ² | 4 ... 20 300 19 ... 28 / 1VA 6 ... 12 0,14 ... 2,5 |
| Environmental conditions Reference temperature Operating temperature range Storage temperature range Environmental protection according to EN 60529 in connected state | °C °C °C | 23 -25 ... +60 -40 ... +70 IP 65 |
| Construction Dimensions incl. mounting unit XKM 078 Weight Material Housing of strain gauge measuring amplifier | mm kg | approx. 1.030 x 150 x 300 approx. 25 1.4301 / 1.4542 Aluminium die cast |

Mounting of the rope

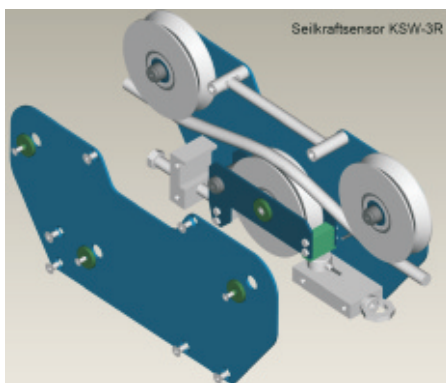

1. Make sure the rope is not loaded
2. Remove side plate
3. Remove screw (M4) under the load cell
4. Pivot block with load cell downwards to allow pivoting down of centre roll
5. Insert wire rope
6. Pivot back centre roll against the rope
7. Span the centre roll with the big screw
8. Pivot back the load cell block and fasten it
9. Release the big screw, make sure it has no contact anymore
10. Mount the side plate

Type code / Order example

| |
|--------------------------|
| Type code |
| KSW-3R/200kN/28mm/4-20mA |

Data sheet KSW-3R • Subject to technical changes • 05/2010