

# POSIROT® PRAS5 Magnetic Angle Sensor with Analog Output

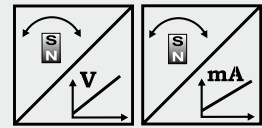

**Magnetic angle sensor 0 - 360° in a flat housing with 66 mm resp. 68.2 mm dia.**

- Measurement range 0 - 360°
- Protection class IP67 / IP69K, optional IP68\*
- Analog output
- With 10 mm shaft or non-contact
- Magnetic measurement principle
- Other outputs available on request
- Seawater proof
- Suitable for use on ocean-going vessels



\* Depth and duration of immersion must be specified!

Specifications	Outputs	U2	Voltage 0.5 ... 10 V
		U6 /5/ 8,25 I1	
	Measurement range		0 ... 15° to 0 ... 360° in 15° increments
	Resolution		0.03 % (60 ... 360); 0.1 % (15 ... 45°)
	Repeatability		±0.03 % (60 ... 360°); ±0.1 % (15 ... 45°)
	Linearity		±0.3 % f.s. (typ.)
	Rated distance sensor / magnet		Depending on the position magnet
	Protection class		IP67/IP69K (connector output with IP69K connector cable); IP68 - on request
	Signal characteristics		CW, CCW
	Material		Stainless steel
	Mounting		Screws M8
	Shock		EN60068-2-27:1993, 100 g/11 ms, 100 shocks
	Vibration		EN60068-2-6:1995, 20 g 10 Hz-2 kHz, 10 cycles
	Life cycle of bearings (shaft version)		100 x 10 <sup>6</sup> revolutions (<1500 r.p.m.)
	Revolutions per minute (shaft version)		Max. 10,000 r.p.m.
	Allowable shaft load		120 N radial, 120 N axial

## Order Code PRAS5

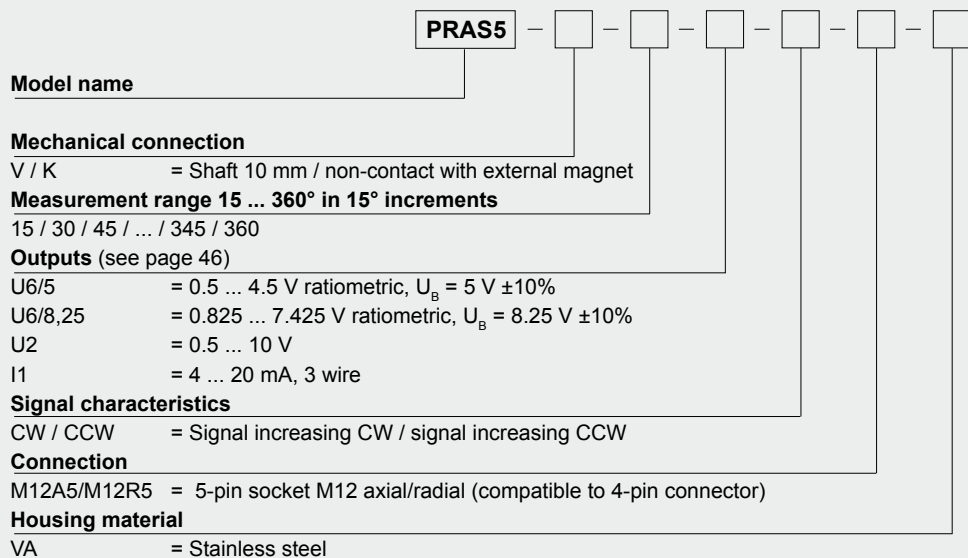

Order code position magnet (see accessories page 53/54)

PRMAG ...

Order code connector cable (see accessories page 90)

KAB-2M-M12/4F/G-LITZE

**Order example: PRAS5 - V - 360 - U6/5 - CW - M12R5 - VA**

**POSIROT®**  
**PRDS5**  
**Magnetic Angle Encoder with SSI Output**



**Magnetic angle sensor 0 - 360° in a flat housing with 66 mm resp. 68.2 mm dia.**

- Measurement range 0 - 360°
- Protection class IP67 / IP69K, optional IP68\*
- Synchronous serial output (SSI)
- With 10 mm shaft or non-contact
- Magnetic measurement principle
- Seawater proof
- Suitable for use on ocean-going vessels

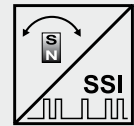

\* Depth and duration of immersion must be specified!

Specifications	Output	Synchronous serial (SSI)
	Measurement range	0 to 360°
	Resolution	12 bit (4096 steps) per revolution
	Repeatability	±0.1° (typ.)
	Linearity	±1°(typ.)
	Rated distance sensor / magnet	Depending on the position magnet
	Protection class	IP67/IP69K (connector output with IP69K connector cable); IP68 - on request
	Code characteristics	CW, CCW
	Material	Stainless steel
	Mounting	Screws M8
	Shock	EN60068-2-27:1993, 100 g/11 ms, 100 shocks
	Vibration	EN60068-2-6:1995, 20 g 10 Hz-2 kHz, 10 cycles
	Life cycle of bearings (shaft version)	100 x 10 <sup>6</sup> revolutions (<1500 r.p.m.)
Revolutions per minute (shaft version)	Max. 10,000 r.p.m.	
Allowable shaft load	120 N radial, 120 N axial	

**Order Code PRDS5**

**Model name** PRDS5 - [ ] - [ ] - [ ] - [ ] - [ ]

**Shaft**  
V = Shaft 10 mm  
K = Non-contact with external magnet

**Output** (see page 49)  
RSSI5V = Synchronous serial output with excitation 5 V DC  
RSSI24V = Synchronous serial output with excitation 10 ... 36 V DC

**Code characteristics**  
CW = Code increasing CW  
CCW = Code increasing CCW

**Connection**  
M12A8/R8 = 8-pin socket M12 axial/radial

**Housing material**  
VA = Stainless steel

Order code position magnet (see accessories page 53/54)

**PRMAG ...**

Order code connector cable (see accessories page 90)

**KAB-2M-M12/8F/G-LITZE**

**Order example: PRDS5 - K - RSSI24V - CW - M12R8 - VA**



**Magnetic angle encoder 0 - 360° in a flat housing with 66 mm resp. 68.2 mm dia.**

- Measurement range 0 - 360°
- Protection class IP67 / IP69K, optional IP68\*
- CANopen output
- With 10 mm shaft or non-contact
- Magnetic measurement principle
- Seawater proof
- Suitable for use on ocean-going vessels

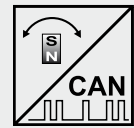

\* Depth and duration of immersion must be specified!

Specifications		
Output		CANopen-Bus (Encoder CiA 406 V 3.2)
Measurement range		0 ... 360°
Resolution		0.05° max.
Linearity		±1° (typ.)
Protection class		IP67/IP69K (connector output with IP69K connector cable); IP68 - on request
Material		Stainless steel
Mounting		Screws M8
Connection		Connector M12 5 pin, radial or axial
Shock		EN60068-2-27:1993, 100 g/11 ms, 100 shocks
Vibration		EN60068-2-6:1995, 20 g/10 Hz-2 kHz, 10 cycles
Life cycle of bearings (shaft version)		100 x 10 <sup>6</sup> revolutions (<1500 r.p.m.)
Revolutions per minute (shaft version)		Max. 10,000 r.p.m.
Allowable shaft load		120 N radial, 120 N axial
EMC, Temperature		Refer to output specification

**Order Code PRDS5**

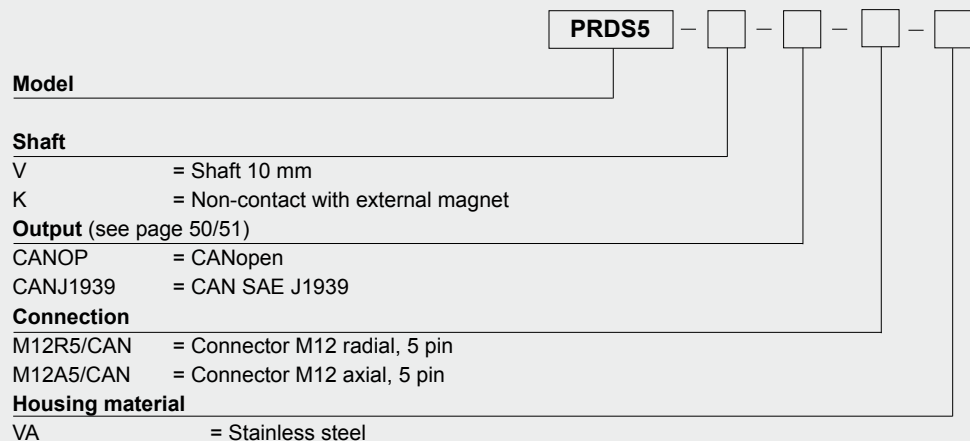

Order code position magnet (see accessories page 53/54)

**PRMAG ...**

Order code connector cable (see accessories page 91 )

**KAB - XM - M12/5F/G - M12/5M/G - CAN**

**Order example: PRDS5 - K - CANOP - M12A5/CAN - VA**

Outline drawing  
PRAS5-K/PRDS5-K  
M12 radial

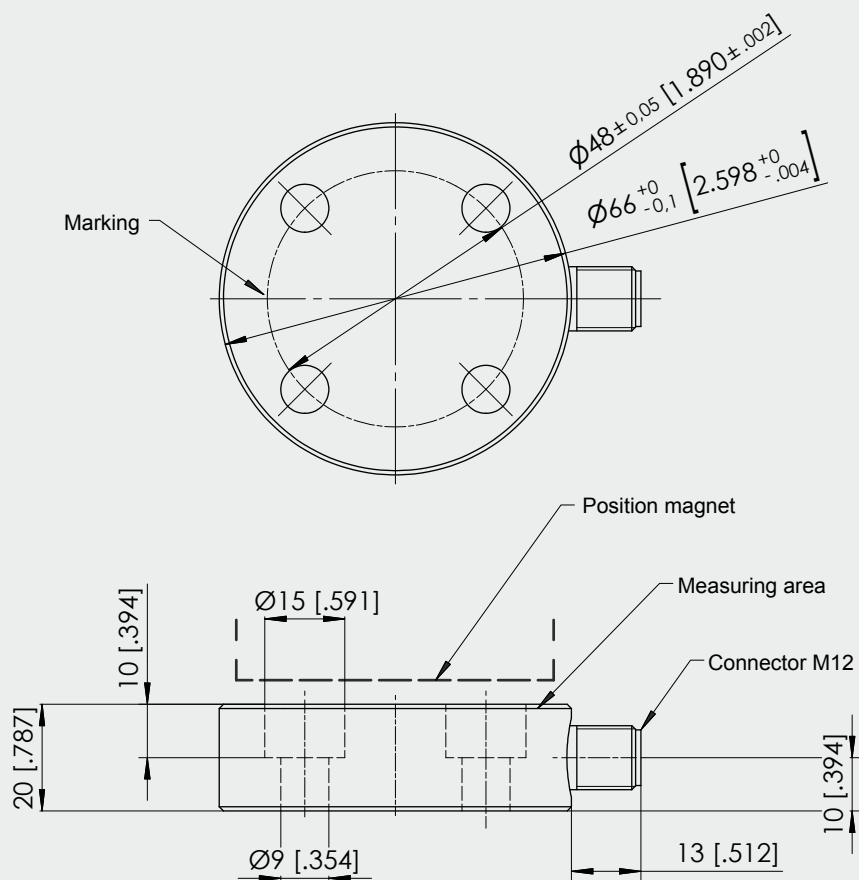

Dimensions in mm [inch]

Dimensions informative only.  
For guaranteed dimensions consult factory.

**POSIROT®**  
**PRAS5/PRDS5**  
**Dimensions**



Outline drawing  
 PRAS5-K/PRDS5-K  
 M12 axial

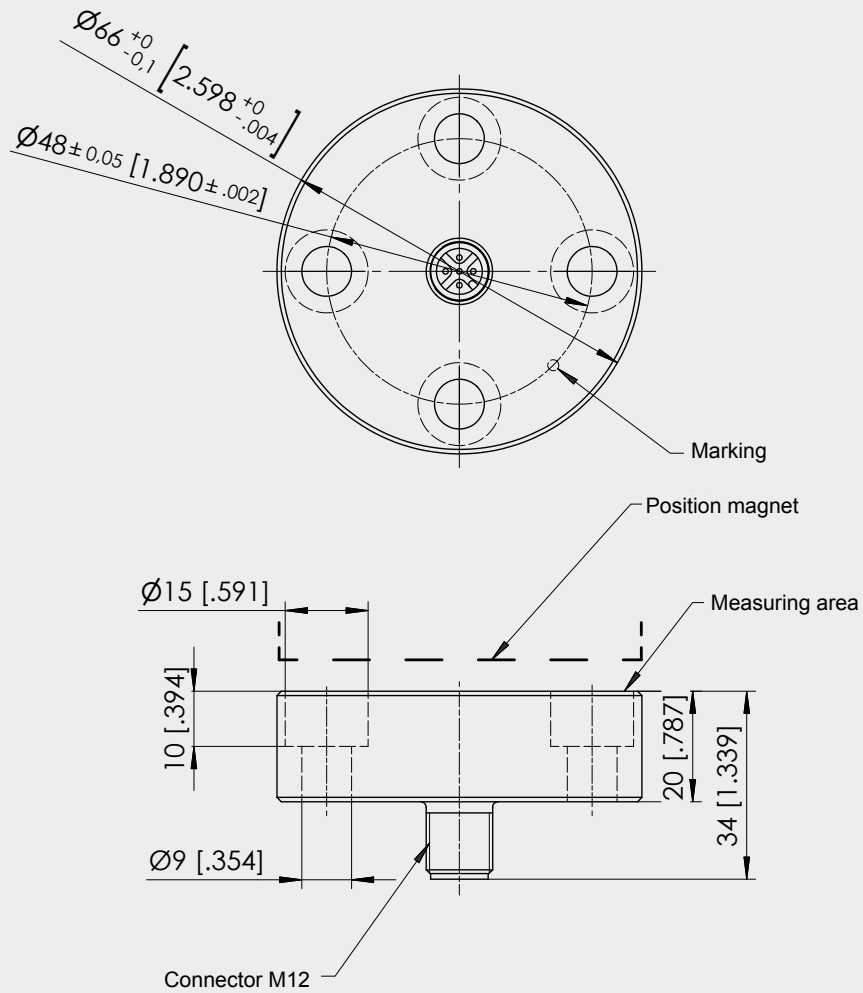

Dimensions in mm [inch]

Dimensions informative only.  
 For guaranteed dimensions consult factory.

**POSIROT®**  
**PRAS5/PRDS5**  
**Dimensions**



**Outline drawing**  
**PRAS5-V, PRDS5-V**  
**M12 radial**

(flange mechanically compatible to the analog angle sensor AWS1)

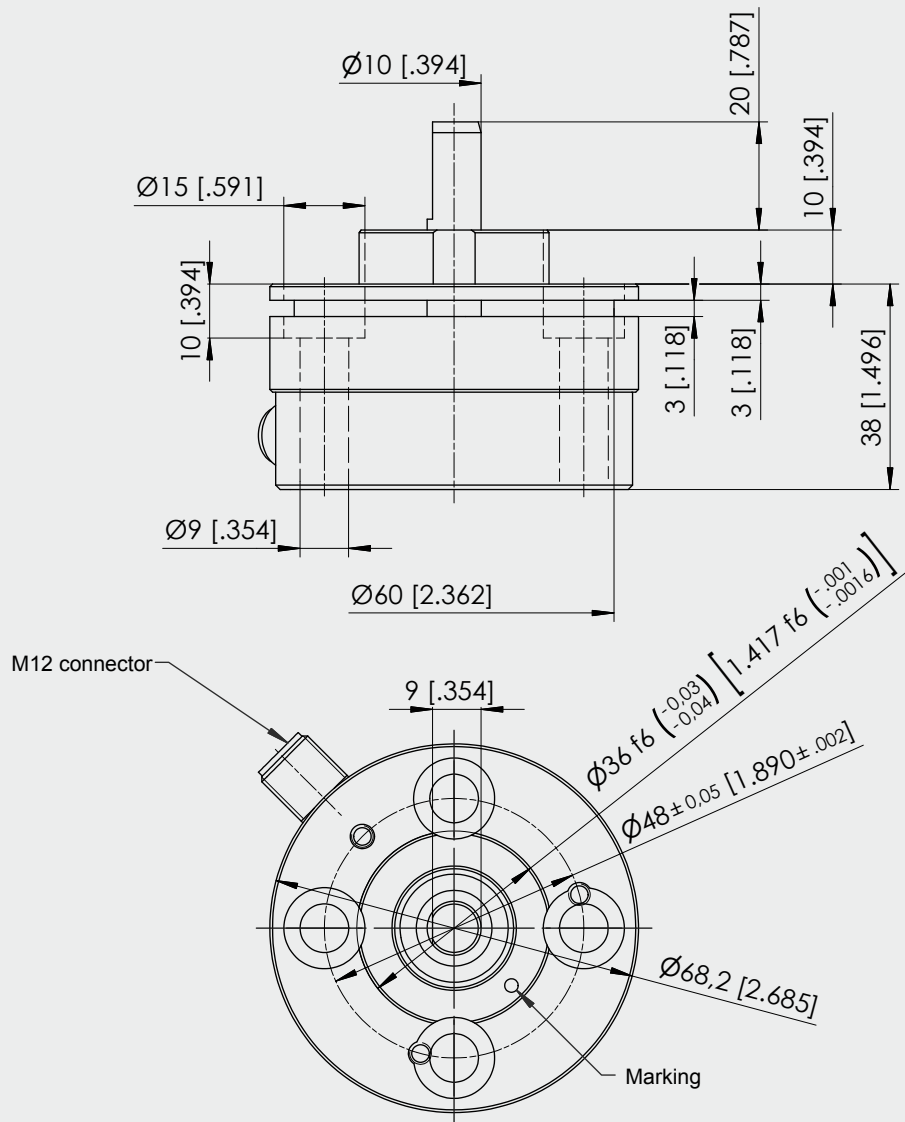

Dimensions in mm [inch]

Dimensions informative only.  
 For guaranteed dimensions consult factory.

**POSIROT®**  
**PRAS5/PRDS5**  
**Dimensions**



**Outline drawing**  
**PRAS5-V, PRDS5-V**  
**M12 axial**

(flange mechanically compatible to the analog angle sensor AWS1)

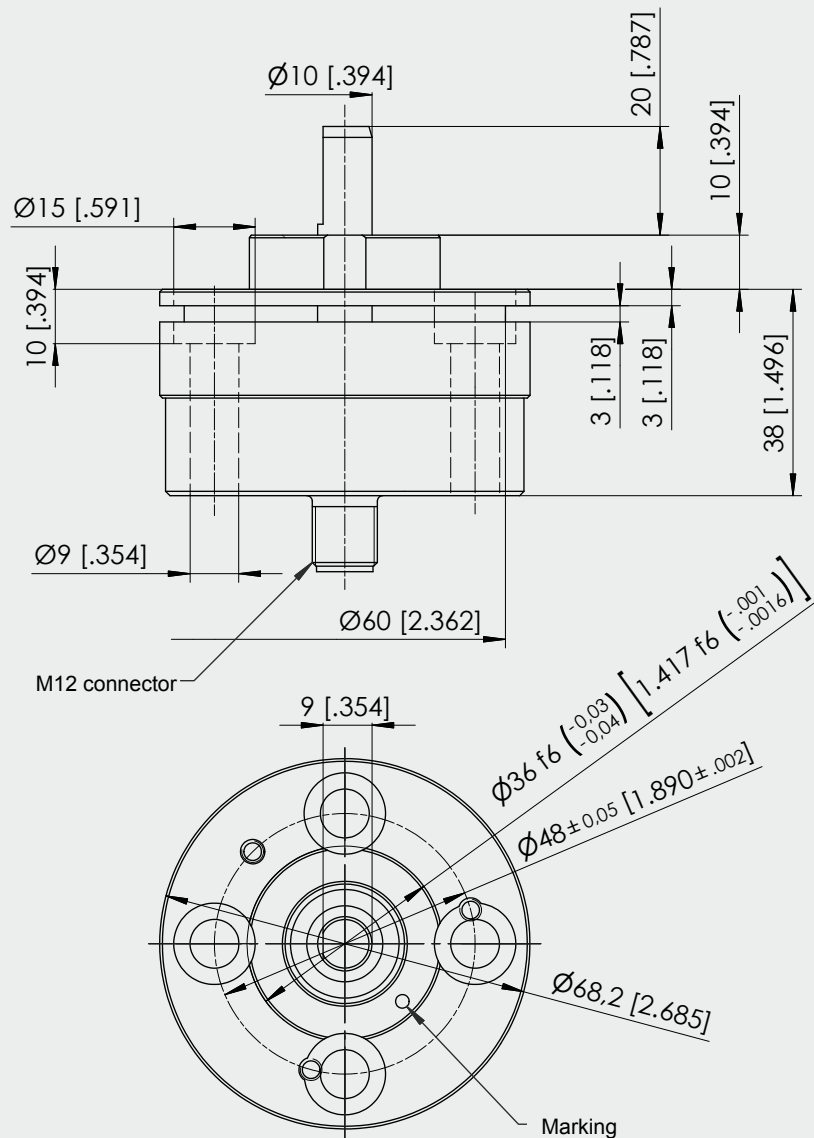

Dimensions in mm [inch]

Dimensions informative only.

For guaranteed dimensions consult factory.

**POSIROT®**  
**PRAS**  
**Analog outputs U2(B), U6 and I1(B)**

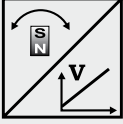
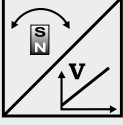
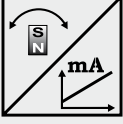

<b>U2; U2B</b> Voltage Output 0.5 ... 10 V 	Excitation voltage	U2: 18 ... 36 V DC; U2B: 11.5 ... 27 V DC
	Excitation current	12 mA typ., 16 mA max.
	Output voltage	0.5 ... 10 V DC
	Output current	2 mA max.
	Measuring rate	1 kHz standard
	Stability (temperature)	±50 x 10 <sup>-6</sup> / °C f.s. (typ.) for 90°...360° ±100 x 10 <sup>-6</sup> / °C f.s. (typ.) for <90°
	Operating temperature	-40 ... +85 °C
	Protection	Reverse polarity, short circuit
EMC	EN61326-1:2006	
<b>U6/5; U6/8,25</b> Voltage Output 10 ... 90% ratiometr. 	Excitation voltage	5V DC ±10 % / 8.25 V DC ±10 %
	Excitation current	8 mA typ., 12 mA max.
	Output voltage	10 ... 90 % of the excitation voltage
	Output current	2 mA max.
	Measuring rate	1 kHz standard
	Stability (temperature)	±50 x 10 <sup>-6</sup> / °C f.s. (typ.) for 90°...360° ±100 x 10 <sup>-6</sup> / °C f.s. (typ.) for <90°
	Operating temperature	-40 ... +85 °C
	Protection	Reverse polarity, short circuit
EMC	EN61326-1:2006	
<b>I1; I1B</b> Current Output 4 ... 20 mA, 3 wire 	Excitation voltage	I1: 18 ... 36 V DC; I1B: 10 ... 18 V DC
	Excitation current	32 mA typ., 36 mA max.
	Load resistor	I1: 500 Ω max.; I1B: 250 Ω max.
	Output current	4 ... 20 mA
	Measuring rate	1 kHz standard
	Stability (temperature)	±50 x 10 <sup>-6</sup> / °C f.s. (typ.) for 90°...360° ±100 x 10 <sup>-6</sup> / °C f.s. (typ.) for <90°
	Operating temperature	-40 ... +85 °C
	Protection	Reverse polarity, short circuit
EMC	EN61326-1:2006	

Other outputs available on request.

**Output signals**

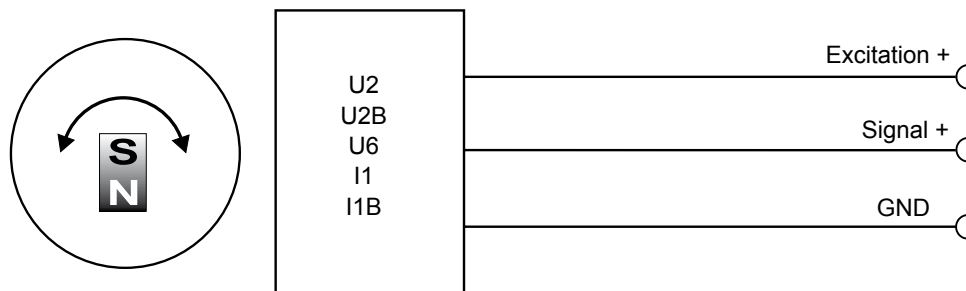

Signal Wiring	Output signals	Connector pin	Cable color
	Excitation +	1	brown
	Signal	2	white
	GND	3	blue
	Do not connect!	4	black
	Do not connect!	5	-

**Connection**

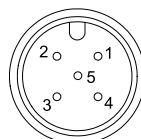

M12A5 / M12R5

View to sensor  
connector



# POSIROT<sup>®</sup> PRDS Output RSSI5V / RSSI24V



<b>RSSI5V / RSSI24V</b> Synchronous serial  	Interface	EIA RS-422
	Excitation voltage	RSSI5V: 5 V DC $\pm 10\%$ ; RSSI24V: 10 ... 36 V DC
	Excitation current	100 mA max. without load
	Clock frequency	100 kHz ... 1 MHz
	Code	Single step Gray code 12 Bit
	Resolution	12 Bit
	Delay between pulse trains	20 $\mu$ s min.
	Stability (temperature)	$\pm 50 \times 10^{-6}$ / $^{\circ}$ C f.s. (typ.)
	Operating temperature	-40 ... +85 $^{\circ}$ C
	Protection	Short circuit
	EMC	EN61326-1:2006

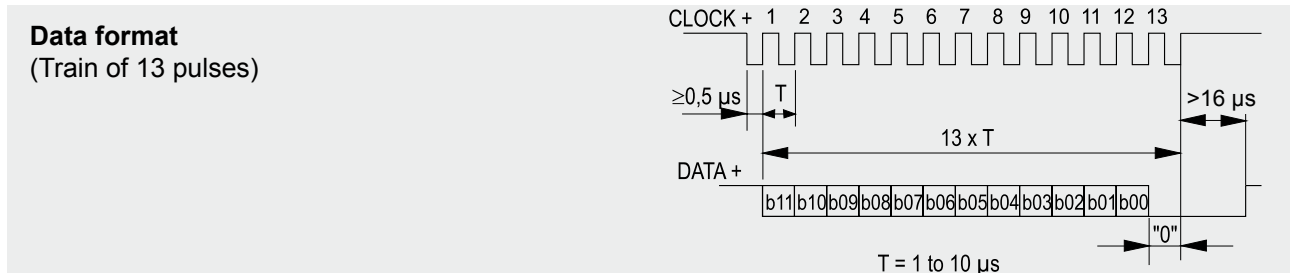

### Recommended processing input circuit

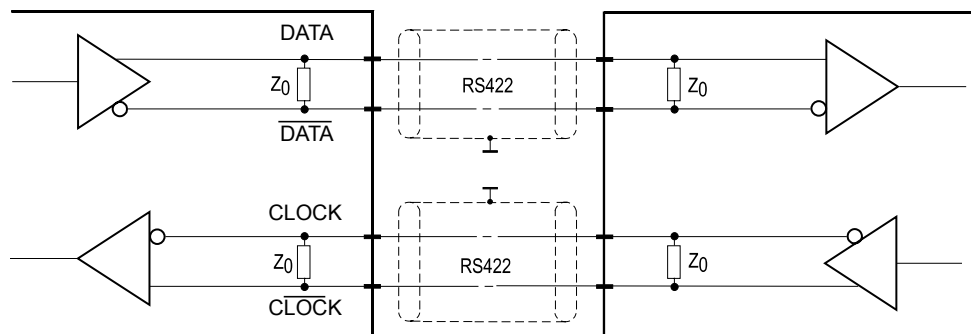

Cable length	Baud rate
50 m	100-1000 kHz
100 m	100-300 kHz

**Note:**  
Extension of the cable length will reduce the maximum transmission rate. The signals CLOCK /CLOCK and DATA/DATA must be connected in a twisted pair cable, shielded per pair and common.

Signal wiring	Signal name	Connector pin no.	Cable color
	Excitation +	1	white
	Excitation GND	2	brown
	CLOCK	3	green
	CLOCK	4	yellow
	DATA	5	grey
	DATA	6	pink

### Connection

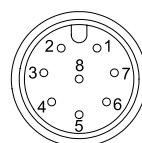

View to sensor connector

M12A8 / M12R8

**Description**                      Magnetic angle encoder with CANopen interface according to CiA 406.

<p><b>CANopen</b></p> 	Communication profile	CANopen CiA 301 V 4.02, Slave
	Device profile	Encoder CiA 406 V 3.2
	Configuration services	Layer Setting Service (LSS), CiA Draft Standard 305 (transmission rate, node id)
	Error Control	Node Guarding, Heartbeat, Emergency Message
	Node ID	Default: 127; programmable via LSS or SDO
	PDO	3 TxPDO, 0 RxPDO, static mapping
	PDO Modes	Event-/Time triggered, Remote-request, Sync cyclic/acyclic
	SDO	1 server, 0 Client
	CAM	8 cams
	Certified	Yes
	Transmission rates	50 kBaud to 1 MBaud, default: 125 kBaud; programmable via LSS or SDO
	Bus connection	M12 connector, 5 ping
	Integrated bus terminating resistor	Optional
	Bus, galvanic isolated	No

<p><b>Specifications</b></p>	Excitation voltage	8 ... 36 V DC
	Excitation current	Typ. 15/30 mA for 24/12 V, max. 100 mA
	Measuring rate	1 kHz (asynchronous)
	Stability (temperature)	±50 x 10 <sup>-6</sup> / °C f.s.
	Repeatability	1 LSB
	Operating temperature	-40 ... +105 °C
	Protection	Reverse polarity, short circuit
	Dielectric strength	1 kV (V AC, 50 Hz, 1 min.)
	EMC Automation	EN61326-1:2006

**Description** Angle encoder according to standard SAE J1939. Customer configuration of operating parameters by Peer-to-Peer. Process data exchange by Broadcast message. Node-Id distribution by address claiming (ACL).

<b>Interface J1939</b> 	CAN specification	ISO 11898, Basic and Full CAN 2.0 B
	Transceiver	24V-compliant, not isolated
	Communication profile	SAE J1939
	Baud rate	250 kbit/s
	Internal termination resistor	120 Ω
	Address	Default 247d, configurable

<b>NAME Fields</b>	Arbitrary address capable	1	Yes
	Industry group	0	Global
	Vehicle system	7Fh (127d)	Non specific
	Vehicle system instance	0	
	Function	FFh (255d)	Non specific
	Function instance	0	
	ECU instance	0	
	Manufacturer	145h (325d)	Manufacturer ID
	Identity number	0nnn	Serial number 21 bit

<b>Parameter Group Numbers (PGN)</b>	Configuration data	PGN EF00h	Proprietary-A (PDU1 peer-to-peer)
	Process data	PGN FFnnh	Proprietary-B (PDU2 broadcast); nn Group Extension (PS) configurable

<b>Specifications</b>	Excitation voltage	8 ... 36 V DC
	Excitation current	Typ. 15/30 mA for 24/12 V, max. 100 mA
	Measuring rate	1 kHz (asynchronous)
	Stability (temperature)	±50 x 10 <sup>-6</sup> / °C f.s.
	Repeatability	1 LSB
	Operating temperature	-40 ... +105 °C
	Protection	Reverse polarity, short circuit
	Dielectric strength	1 kV (V AC, 50 Hz, 1 min.)
	EMC	EN61326-1:2006

<b>Signal wiring / connection</b>	<b>Signal name</b>	<b>Connector pin</b>	<b>Wire color</b>
	Shield	1	Black+grey
	Excitation +	2	White
	GND	3	Brown
	CAN-H	4	Green
	CAN-L	5	Yellow

View to sensor connector

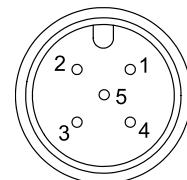

**POSIROT<sup>®</sup>**  
**PRAS/PRDS**  
**Characteristics for magnetic angle sensors**



**Output signal**  
 (CW increasing)

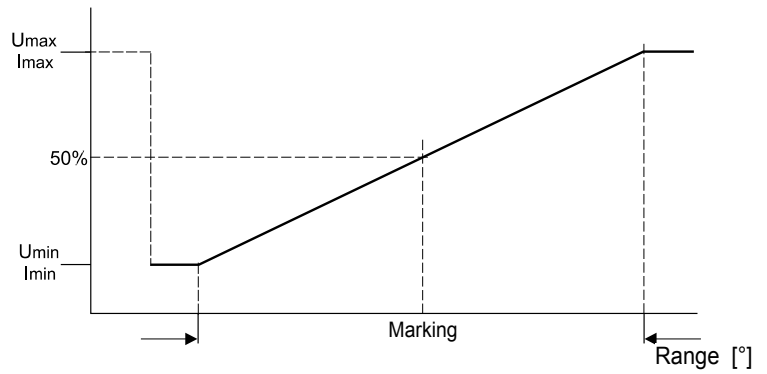

**Output signal**  
 (CCW increasing)

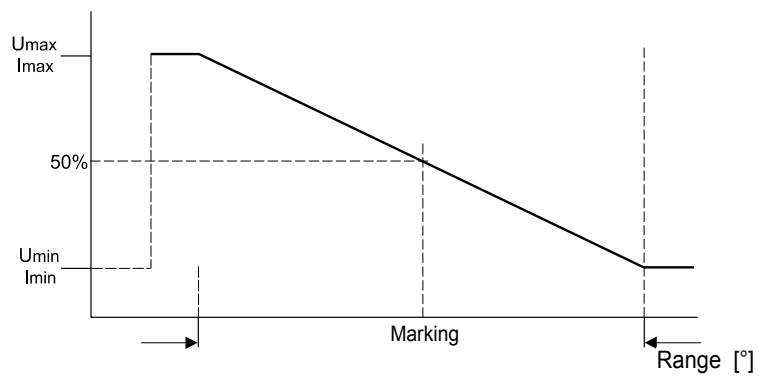

**Example angular**  
**range 90°**

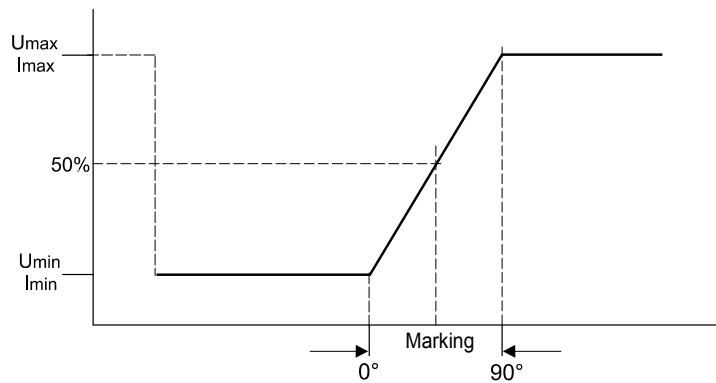

**Example angular**  
**range 360°**

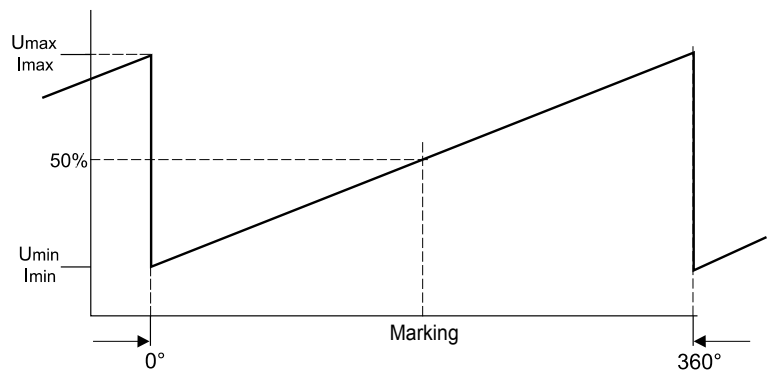

**PRMAG20**

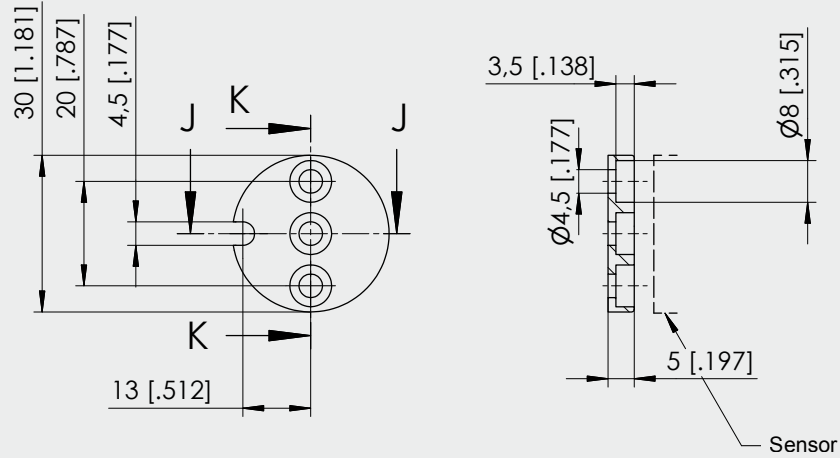

Weight 11 g approx.,  
 moment of inertia 1.2 kgmm<sup>2</sup>

A misalignment of the position magnet  
 has an effect on the linearity

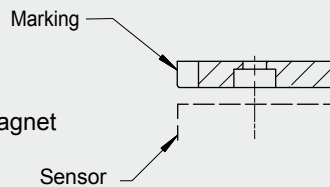

**PRMAG21**

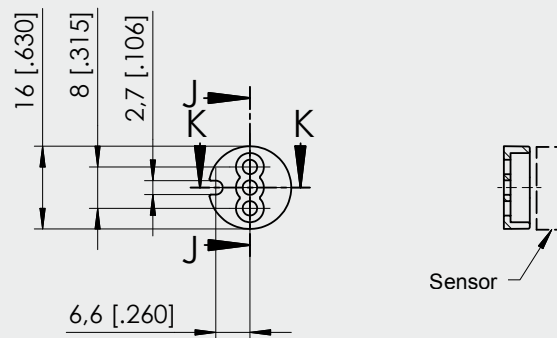

Weight 3 g approx.,  
 moment of inertia 0.1 kgmm<sup>2</sup>

A misalignment of the position magnet  
 has an effect on the linearity

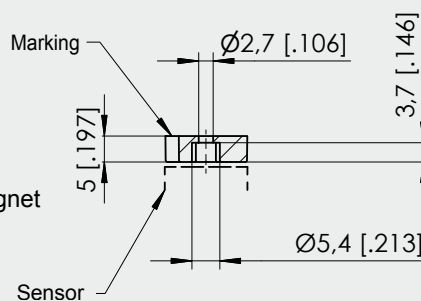

Dimensions in mm [inch]

Dimensions informative only

For guaranteed dimensions please consult factory

**PRMAG22**

Weight 17 g approx.,  
 moment of inertia 3 kgmm<sup>2</sup>

A misalignment of the position magnet  
 has an effect on the linearity

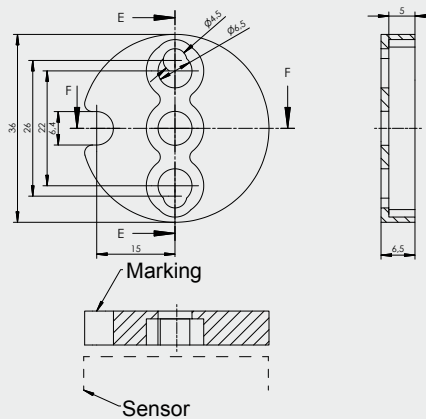

**PRMAG5Z**

Weight 100 g approx.,  
 moment of inertia 55 kgmm<sup>2</sup>

A misalignment of the position magnet  
 has an effect on the linearity

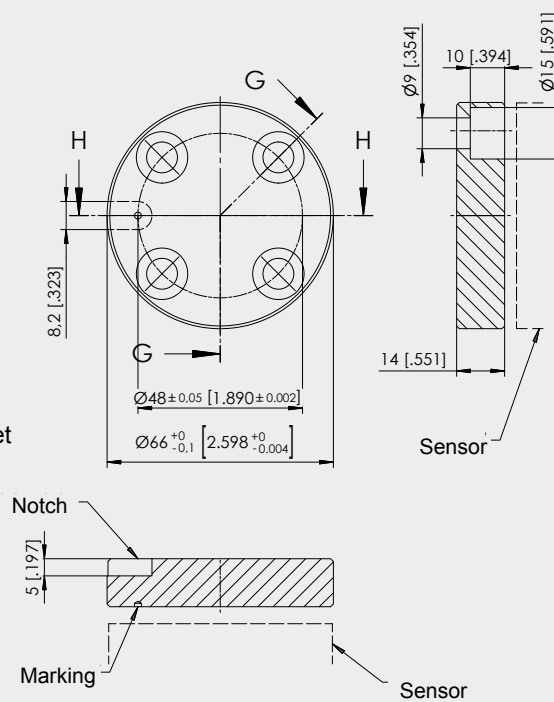

Dimensions in mm [inch]

Dimensions informative only  
 For guaranteed dimensions please consult factory

**Connector cable for POSIROT®-POSITILT® sensors**  
4 pins M12

Suitable for 5-pin sensor connectors M12A5 and M12R5

The 4-core screened cable is supplied with a mating 4-pin 90° M12 connector at one end and 4 wires at the other end. Available lengths are 2, 5 and 10 m.

Order code:

**KAB - XM - M12/4F/W - LITZE**

IP69K: **KAB - XM - M12/4F/W/69K - LITZE**

Length in m

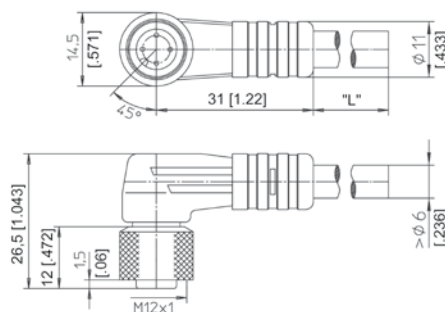

**Connector cable for POSIROT®-POSITILT® sensors**  
4 pins M12

Suitable for 5-pin sensor connectors M12A5 and M12R5

The 4-core screened cable is supplied with a mating 4-pin M12 connector at one end and 4 wires at the other end. Available lengths are 2, 5 and 10 m.

Order code:

**KAB - XM - M12/4F/G - LITZE**

IP69K: **KAB - XM - M12/4F/G/69K - LITZE**

Length in m

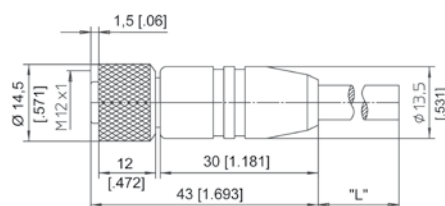

Signal wiring M12, 4 pin	Connector pin / cable color			
	1	2	3	4
	Brown	White	Blue	Black

**Connector cable for POSIROT®-POSITILT® sensors**  
8 pins M12

The 8-core screened cable is supplied with a mating 8-pin 90° M12 connector at one end and 8 wires at the other end. Available lengths are 2, 5 and 10 m.

Order code:

**KAB - XM - M12/8F/W - LITZE**

IP69K: **KAB - XM - M12/8F/W/69K - LITZE**

Length in m

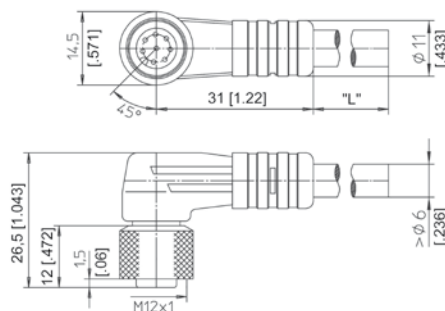

**Connector cable for POSIROT®-POSITILT® sensors**  
8 pins M12

The 8-core screened cable is supplied with a mating 8-pin M12 connector at one end and 8 wires at the other end. Available lengths are 2, 5 and 10 m.

Order code:

**KAB - XM - M12/8F/G - LITZE**

IP69K: **KAB - XM - M12/8F/G/69K - LITZE**

Length in m

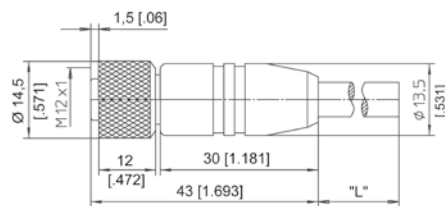

Signal wiring M12, 8 pin	Connector pin / cable color							
	1	2	3	4	5	6	7	8
	White	Brown	Green	Yellow	Grey	Pink	Blue	Red

**Connector/bus cable  
for POSIROT®-  
POSITILT® sensors**  
5 pin M12  
CAN bus

The 5-lead shielded cable is supplied with a female 5-pin M12 connector at one end and a male 5-pin M12 connector at the other end. Available lengths are 2, 5 and 10 m.

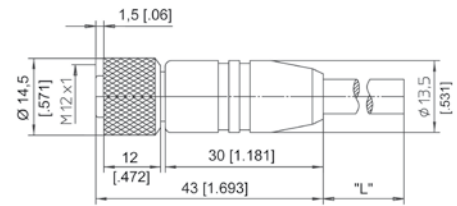

Order code:

**KAB - XM - M12/5F/G - M12/5M/G - CAN**

**IP69K: KAB - XM - M12/5F/G/69K - M12/5M/G/69K - CAN**

Length in m

**T-piece for bus cable**  
5 pin M12  
CAN bus

Order code:

**KAB - TCONN - M12/5M - 2M12/5F - CAN**



**Terminating  
resistance**  
5 pin M12  
CAN bus

Order code:

**KAB - RTERM - M12/5M/G - CAN**

