

- Elevate caratteristiche metrologiche
- Compensazione ai carichi fuori asse  $\leq 0.005\%$  F.S.
- Bassa sensibilità ai piani di appoggio  $\leq 0.002\%$  F.S.
- Facile applicazione a trazione e compressione.
- Maneggevole grazie al peso ridotto ( $\sim 1.7$ kg).



Nati dall'esigenza di estendere a portate più basse le ben note e apprezzate caratteristiche metrologiche della serie  $\mu$ KAL, questi trasduttori sono in grado di stimare le incertezze tra le diverse macchine campioni di forza dei laboratori ACCREDIA e i campioni nazionali. Si prestano quindi ad essere impiegati come Campioni di Prima linea o di trasferimento tra Laboratori, enti di ricerca, e aziende che lavorano in regime di Qualità o come sistema di riferimento su macchine campioni di forza, macchine prova materiali e banchi prova.

- *Excellent metrological features*
- *Off-center loads compensation  $\leq 0.005\%$  F.S.*
- *Low sensitivity to supporting surfaces  $\leq 0.002\%$  F.S.*
- *Easy use for tension and compression application.*
- *Easy to be handled thanks to its reduced weight ( $\sim 1.7$ kg).*

Designed due to the need of extending to the lower ranges the well known and appreciated metrological characteristics of  $\mu$ KAL series, these transducers are able to value the uncertainties among the different sample machines of ACCREDIA laboratories and the National Standards. They are therefore suitable to be employed as First Line or Transfer Samples among laboratories, research bodies and companies which work following Quality procedures or as a reference system on force sample machines, materials test machines and test benches.



Certificato di Taratura ACCREDIA  
**A RICHIESTA**

LAT N° 093  
**Calibration Centre**  
The products are NOT covered by accreditation

ACCREDIA Calibration Certificate  
**ON REQUEST**



## Dimensioni *Dimensions*

[mm]



CODE (Class 00)	CODE (Class 05)	CODE (Class 1)	LOAD	M
CUKAL50NI005	CUKAL50NI055	CUKAL50NI15	50N	M8
CUKAL100NI005	CUKAL100NI055	CUKAL100NI15	100N	
CUKAL200NI005	CUKAL200NI055	CUKAL200NI15	200N	
CUKAL500NI005	CUKAL500NI055	CUKAL500NI15	500N	
CUKAL1KNI005	CUKAL1KNI055	CUKAL1KNI15	1 kN	M12
CUKAL2KNI005	CUKAL2KNI055	CUKAL2KNI15	2 kN	
CUKAL3KNI005	CUKAL3KNI055	CUKAL3KNI15	3 kN	
CUKAL5KNI005	CUKAL5KNI055	CUKAL5KNI15	5 kN	

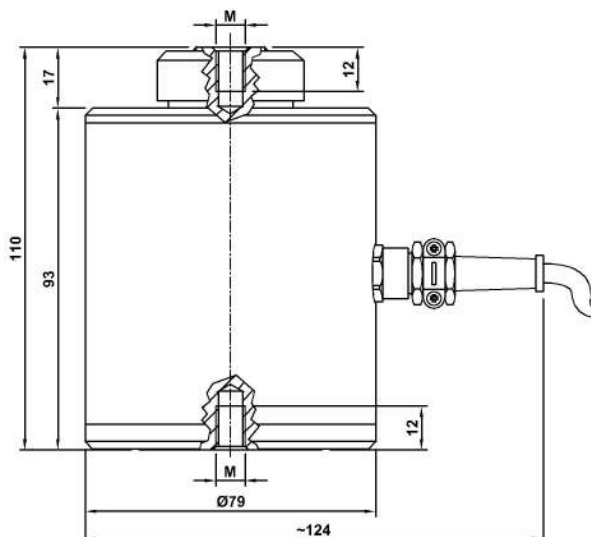

## Dati Tecnici

## Technical Data



Classe di precisione: ISO 376	Accuracy class: ISO 376	00	0.5	1
CARICO NOMINALE	NOMINAL LOAD	50N-100N-200N-500N-1kN-2kN-3kN-5kN		
ERRORI RELATIVI (al valore letto)	RELATIVE ERRORS (at reading)			
a) ripetibilità 0°-120°-240° (b)	a) repeatability 0°-120°-240° (b)	≤ ±0.020% <sup>(1)</sup>	≤ ±0.045% <sup>(1)</sup>	≤ ±0.080% <sup>(1)</sup>
b) interpolazione (fc)	b) interpolation (fc)	≤ ±0.020% <sup>(1)</sup>	≤ ±0.040% <sup>(1)</sup>	≤ ±0.050% <sup>(1)</sup>
c) reversibilità (u)	c) reversibility (u)	≤ ±0.030% <sup>(1)</sup>	≤ ±0.050% <sup>(1)</sup>	≤ ±0.090% <sup>(1)</sup>
d) zero (fo)	d) zero (fo)	≤ ±0.005% F.S.	≤ ±0.010% F.S.	≤ ±0.010% F.S.
LINEARITA'	LINEARITY		≤ ±0.02% F.S.	
ISTERESI	HYSTERESIS		≤ ±0.02% F.S.	
EFFETTO DELLA TEMPERATURA (10°C)	TEMPERATURE EFFECT (10°C)			
a) sullo zero	a) on zero		≤ ±0.015% F.S.	
b) sulla sensibilità	b) on sensitivity		≤ ±0.010% F.S.	
SENSIBILITA' NOMINALE	NOMINAL SENSITIVITY		2mV/V <sup>(2)</sup>	
TOLLERANZA DI CALIBRAZIONE	CALIBRATION TOLERANCE		≤ ±0.1% F.S.	
RESISTENZA DI INGRESSO	INPUT RESISTANCE		350±2Ω	
RESISTENZA DI USCITA	OUTPUT RESISTANCE		352±2Ω	
RESISTENZA DI ISOLAMENTO	INSULATION RESISTANCE		> 5 GΩ	
BILANCIAMENTO DI ZERO	ZERO BALANCE		≤ ± 0.5 % F.S.	
ALIMENTAZIONE DI RIFERIMENTO	REFERENCE POWER SUPPLY		10 V	
ALIMENTAZIONE NOMINALE	NOMINAL POWER SUPPLY		1-15 V	
ALIMENTAZIONE MAX.	MAXIMUM POWER SUPPLY		18 V	
VALORI MECCANICI LIMITE RIFERITI AL CARICO NOMINALE :	MECHANICAL LIMIT VALUES REFERRED TO NOMINAL LOAD :			
a) carico di servizio	a) service load		120%	
b) carico limite	b) max permissible load		150%	
c) carico di rottura	c) breaking load		>300%	
d) massimo carico trasversale	d) max transverse load		100%	
e) carico dinamico limite	e) max permissible dynamic load		75%	
FRECCIA MAX. AL CARICO NOMINALE	DISPLACEMENT AT NOMINAL LOAD		~ 0.2 mm	
TEMPERATURA DI RIFERIMENTO	REFERENCE TEMPERATURE		+23°C	
CAMPO NOMINALE DI TEMPERATURA	TEMPERATURE NOMINAL RANGE		-10/+40 °C	
TEMPERATURA DI ESERCIZIO	SERVICE TEMPERATURE		-10/+70 °C	
TEMPERATURA DI STOCCAGGIO	STORAGE TEMPERATURE		-20/+80 °C	
PESO	WEIGHT		~1.7 kg	
CLASSE DI PROTEZIONE (EN 60529)	PROTECTION CLASS (EN 60529)		IP40	
MATERIALE CONTENITORE	CASE EXECUTION MATERIAL		Acciaio inox / Stainless Steel	
LUNGHEZZA CAVO	CABLE LENGTH		5m	

<sup>(1)</sup> Errori percentuali calcolati al valore letto, min. 1/10 del carico nominale  
Percentage errors referred to reading, min. 1/10 of the nominal load.

<sup>(2)</sup> Calibrazione eseguita in **COMPRESSIONE**.  
Calibration performed in **COMPRESSION**.

A richiesta calibrazioni in kg  
kg calibrations on request.

A richiesta classificazioni secondo **ASTM E74**.  
Classifications according **ASTM E74** on request.

## Collegamenti Elettrici

## Electrical Connections

Cavo schermato PVC 80°C, Ø 5.2mm a 6 conduttori Ø 0.25mm<sup>2</sup> stagnati.

PVC 80°C shielded cable, Ø 5.2mm with 6 tinned Ø 0.25mm<sup>2</sup> conductors.

Transducer	OUTPUT	CABLE	CAVO	MIL7M (optional)
	EXCITATION+	Red	Rosso	C
	SENSE+	Orange	Arancione	F
	OUTPUT+	White	Bianco	A
	EXCITATION -	Black	Nero	B
	SENSE-	Blue	Blu	G
	OUTPUT-	Yellow	Giallo	D
-----	Shield*	Schermo*	E	

\* Collegato al corpo del trasduttore. / Connected to the body of the transducer.

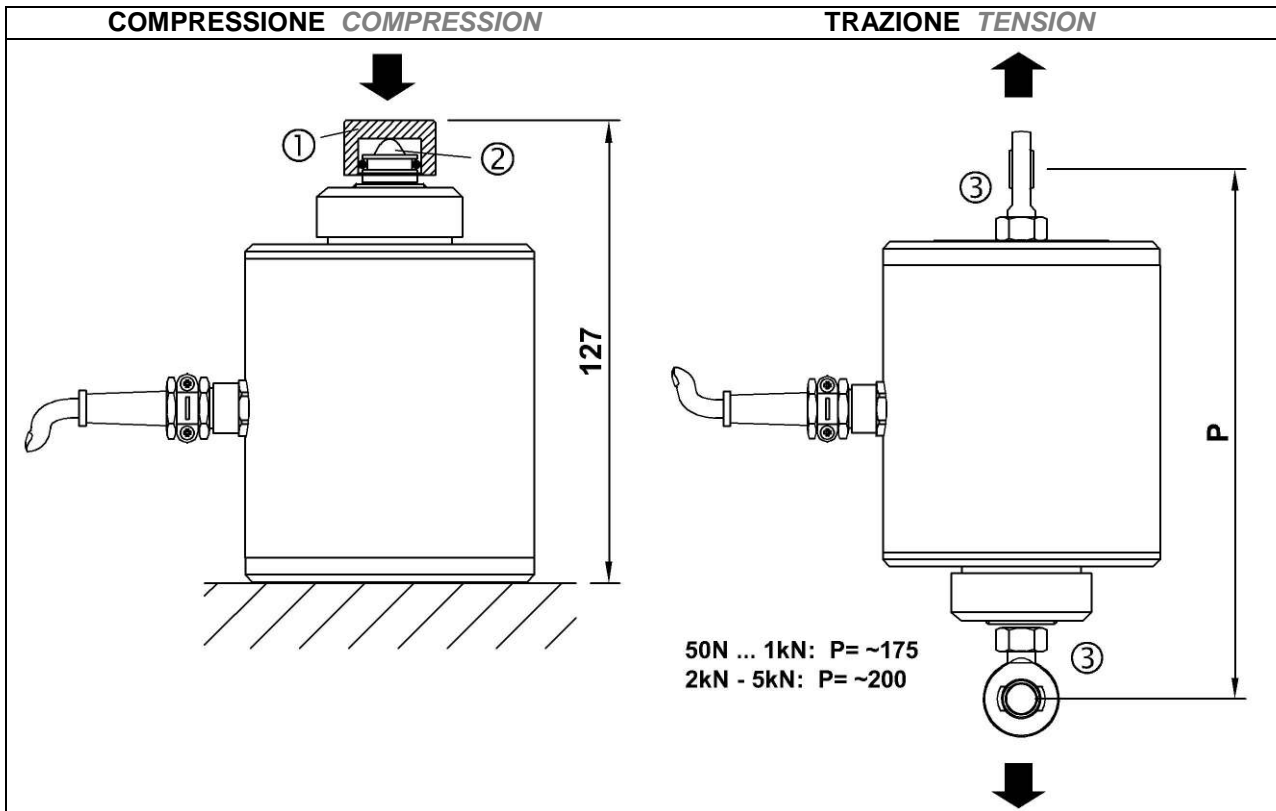

**ATTENZIONE**

Verificare che gli accessori siano correttamente serrati.



Per le basse portate non usare chiavi.



**WARNING**

Check that accessories are correctly tightened.



For low load do not use wrenches.

**Accessori Accessories**



$\mu$ KAL:	CODE		ACCESSORIES (optional):	ACCESSORI (opzionali):
50, 100, 200, 500 N 1kN	CTIC13	①	Loading head.	Testa di carico.
	CTS18M8	②	Spherical loading head.	Testa di carico sferica.
	CACCEM8	③	Knuckle joints.	Teste a snodo sferico.
2kN, 3kN, 5kN	CTIC13	①	Loading head.	Testa di carico.
	CTS18M12	②	Spherical loading head.	Testa di carico sferica.
	CACCEM12	③	Knuckle joints.	Teste a snodo sferico.

**Applicazioni in accordo alla UNI EN ISO 376**  
**Applications according to UNI EN ISO 376**

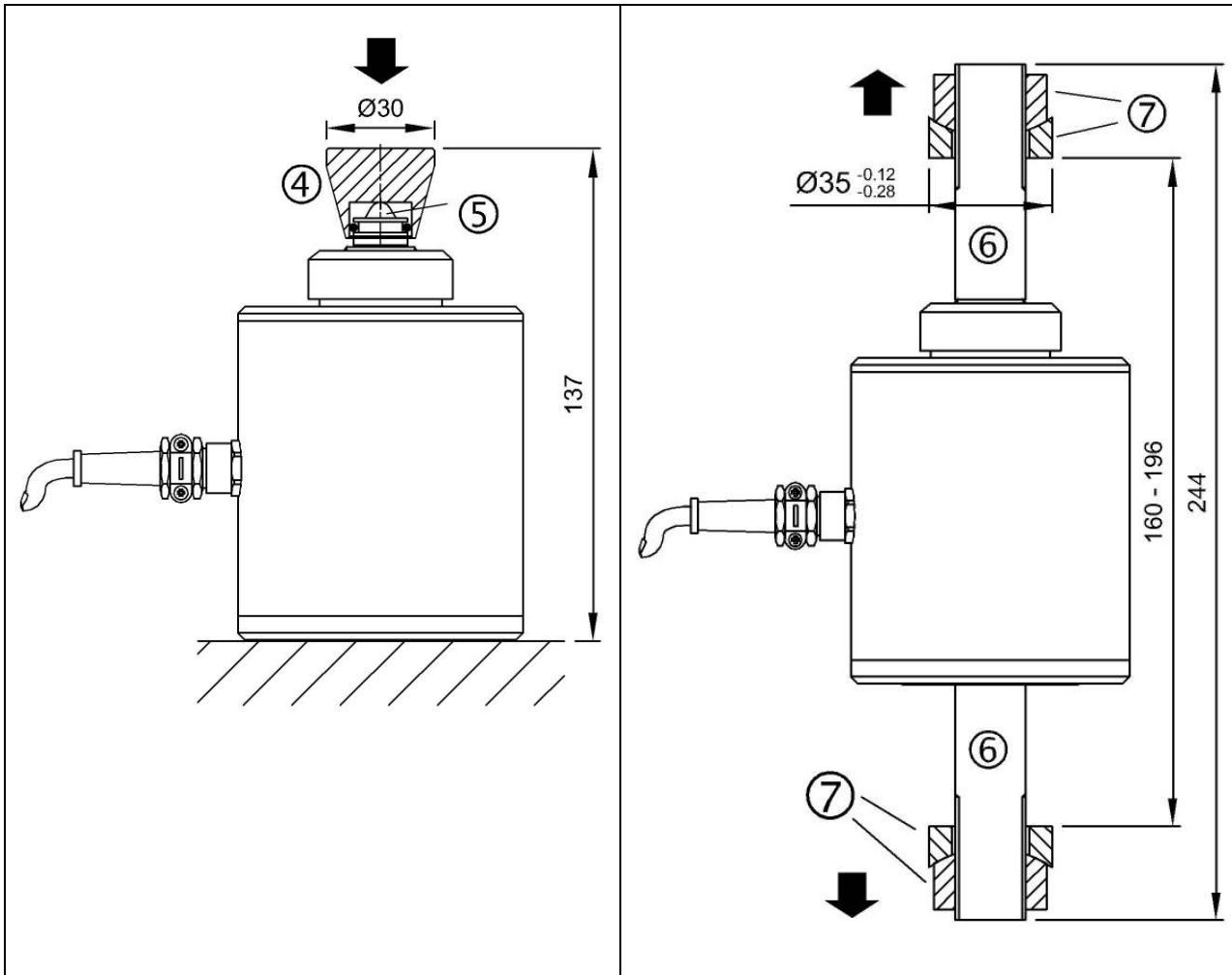

Verificare che gli accessori siano correttamente serrati.



Per le basse portate non usare chiavi.

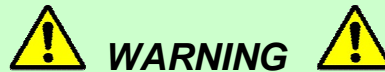

Check that accessories are correctly tightened.



For low load do not use wrenches.

**Accessori Accessories**



Codici Codes	
<i>Tension set</i>	<i>Compression set</i>
(⑥+⑦) + (⑥+⑦)	(④+⑤)
CTISO5 + CTISO5	CCISO5

**AEP transducers**



**Dasa-Rägister**  
 EN ISO 9001:2008  
 IQ-1100-01



LAT N° 093  
**Calibration Centre**  
 The products are NOT covered by accreditation



**Production Quality Assurance Certified n° TUV 06 ATEX 553793 Q**

41126 Cognento (MODENA) Italy Via Bottego 33/A Tel:+39-(0)59-346441 Fax:+39-(0)59-346437 E-mail: aep@aep.it

Al fine di migliorare le prestazioni tecniche del prodotto, la società si riserva di apportare variazioni senza preavviso.  
 In order to improve the technical performances of the product, the company reserves the right to make any change without notice.